

Installation and Operation Instructions for

Mighty Therm

Hydronic Boilers

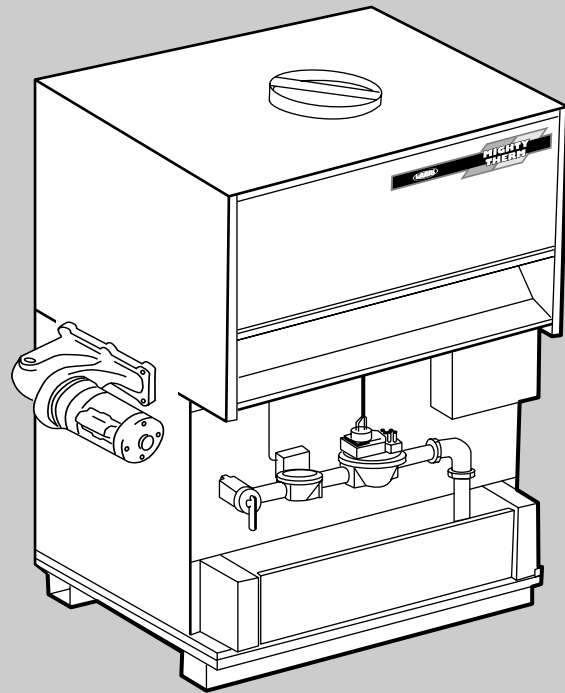
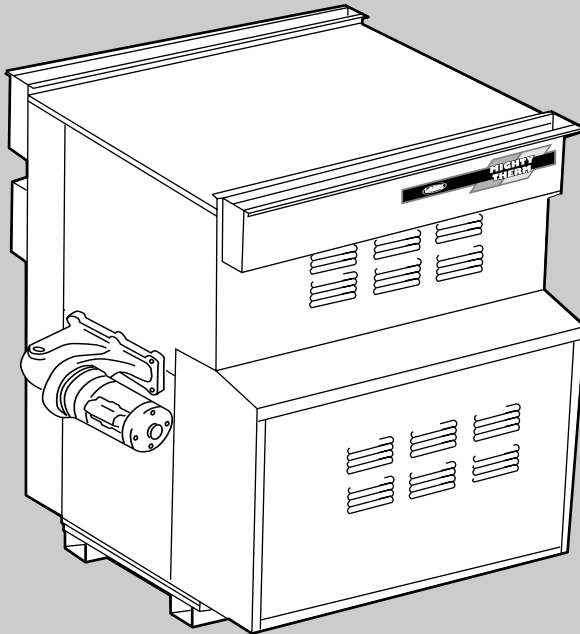

Models HH and PH

Sizes 500-1825

These instructions are to be stored in the pocket provided on the boiler

FOR YOUR SAFETY: This product must be installed and serviced by a professional service technician, qualified in hot water boiler installation and maintenance. Improper installation and/or operation could create carbon monoxide gas in flue gases which could cause serious injury, property damage, or death. Improper installation and/or operation will void the warranty.

⚠ WARNING

If the information in this manual is not followed exactly, a fire or explosion may result causing property damage, personal injury or loss of life.

Do not store or use gasoline or other flammable vapors and liquids in the vicinity of this or any other appliance.

WHAT TO DO IF YOU SMELL GAS

- Do not try to light any appliance.
- Do not touch any electrical switch; do not use any phone in your building.
- Immediately call your gas supplier from a nearby phone. Follow the gas supplier's instructions.
- If you cannot reach your gas supplier, call the fire department.

Installation and service must be performed by a qualified installer, service agency, or gas supplier.

TABLE OF CONTENTS

SECTION 1.

General Information

1A.	Introduction	3
1B.	Boiler Identification	3
1C.	Flow Requirements	3
1D.	Variable Water Flow Systems	4
1E.	Warning Regarding Chilled Water Systems	5
1F.	Freeze Protection	5

SECTION 2.

Installation

2A.	Boiler Placement	6
2B.	Installation of Indoor Boilers	6
2B-1.	Combustion Air Supply	6
2B-2.	Venting	8
2C.	Installation of Outdoor Boilers	9
2D.	Gas Supply and Piping	9
2E.	Electrical Wiring	10
2F.	Water Piping of System	11
2G.	Filling Fully-Connected System	11

SECTION 3.

Operation

3A.	Controls - General	12
3B.	Initial Start-Up	13
3C.	To Start Up System	13
3D.	To Turn Off Boiler	14
3E.	To Shut Down System	14

SECTION 4.

Maintenance

.....	14
-------	----

SECTION 5.

Troubleshooting and Analysis of Service Problems

.....	16
-------	----

SECTION 6.

Parts Descriptions and Order Numbers

.....	18
-------	----

SECTION 7.

Outdoor Parts Descriptions and Order Numbers

.....	26
-------	----

SECTION 8.

Optional Parts Descriptions and Order Numbers

.....	28
-------	----

SECTION 1. General Information

1A. Introduction

This manual provides information for the installation and operation of Laars hydronic boilers. It is strongly recommended that all application and installation procedures be reviewed completely before proceeding with the installation. Consult the Laars factory, or local factory representative with any problems or questions regarding this equipment. Experience has shown that most problems are caused by improper installation not system design.

Some accessory items are shipped in separate packages. Verify receipt of all items listed on the package slip. Inspect everything for possible damage upon delivery, and inform the carrier of any shortages or impairments. Any such claims should be filed with the carrier. The carrier, not the shipper, is responsible for shortages and damage to the shipment whether visible or concealed.

IMPORTANT WARNING:

The model HH and PH hydronic boilers must be installed in accordance with the procedures outlined in this manual. The warranty does not apply to boilers not installed or operated in accordance with these procedures. Consult local building and safety codes before proceeding with work. The installation must

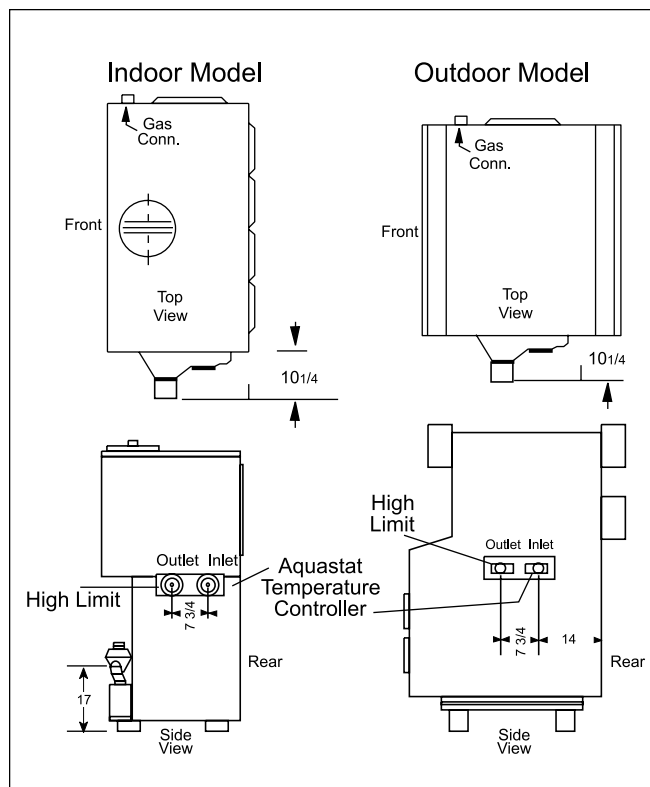

Figure 1. Boiler Configuration.

conform to the requirements of the authority having jurisdiction or, in the absence of such requirements, to the latest edition of the National Fuel Gas Code; ANSI Z223.1, National Electrical Code ANSI/NFPA 70 and/ or in Canada CAN 1 -13149 requirement.

When required by the authority having jurisdiction, the installation must conform to American Society of Mechanical Engineers safety codes for controls and safety devices for automatically fired boilers No. CSD-1, and in Canada CGA 3.3. Any modification to the boiler, its gas controls, gas orifices, wiring or draft diverter may void the Laars warranty. If field conditions require such modifications, consult factory.

1B. Boiler Identification

Consult rating plate on the boiler. The following example simplifies the boiler identification.

1	2	3	4	5	6
PH	1670	I	N	09	L

- (1) Basic boiler model (see descriptions below).
- (2) Input rate X 1000 BTU/hr.
- (3) Indoor (I) or Outdoor (E) installation.
- (4) Gas type: Natural (N) or Propane (P).
- (5) Ignition system: I.I.D. (09) or continuous pilot (16). Special option: I.I.D. (04) 115 volts.
- (6) Firing modes:
 - On/Off (C)
 - 2-stage (K)
 - 4-stage (L)
 - Mechanical Modulation (H)
 - Motorized Modulation (F)
 - Motorized On/Off (R)
 - Motorized 2-stage (T).

Model HH hydronic heating boilers. There must be a field installed pump to circulate water.

Model PH hydronic heating boilers are basically the same as the HH models except that the PH boilers come with integrally mount pumps. Pumps are sized for pressure drop through the heat exchanger and short runs of pipe for primary-secondary systems.

Laars hydronic boilers are available in two configurations: an indoor version and an outdoor version. Both are available from the factory (see Figure 1).

1C. Flow Requirements

All low volume hydronic boilers must have continuous flow through the heat exchanger for proper operation. The system pump must be capable of developing sufficient pressure to overcome the

Design Temperature Rise Across The Boiler																	
Indoor Sizes	Outdoor Sizes	20°F 11°C				25°F 14°C				30°F 17°C				35°F 19°C			
		Flow		H/L		Flow		H/L		Flow		H/L		Flow		H/L	
		GPM	l/s	Ft.	m	GPM	l/s	Ft.	m	GPM	l/s	Ft.	m	GPM	l/s	Ft.	m
500	—	38	2.4	1.4	0.4	31	2.0	1.1	0.3	26	1.6	0.9	0.3	22	1.4	0.6	0.2
—	500	41	2.6	1.7	0.5	33	2.1	1.1	0.3	27	1.7	0.9	0.3	23	1.5	0.7	0.2
600	—	49	3.1	2.3	0.7	39	2.5	1.6	0.5	32	2.0	1.1	0.3	28	1.8	0.9	0.3
—	600	49	3.1	2.3	0.7	39	2.5	1.6	0.5	32	2.0	1.1	0.3	28	1.8	0.9	0.3
715	—	56	3.5	2.5	0.8	45	2.8	1.9	0.6	37	2.3	1.5	0.5	32	2.0	1.0	0.3
—	715	58	3.7	3.2	1.0	47	3.0	2.2	0.7	39	2.5	1.6	0.5	33	2.1	1.1	0.3
850	—	66	4.2	3.4	1.0	53	3.3	2.5	0.8	44	2.8	2.0	0.6	38	2.4	1.4	0.4
—	850	69	4.4	3.6	1.1	55	3.5	3.1	0.9	46	2.9	2.2	0.7	39	2.5	1.6	0.5
1010	—	79	5.0	4.7	1.4	63	4.0	3.4	1.0	53	3.3	2.7	0.8	45	2.8	1.9	0.6
—	1010	82	5.2	5.0	1.5	66	4.2	3.6	1.1	55	3.5	3.1	0.9	47	3.0	2.2	0.7
1200	—	94	5.9	6.5	2.0	75	4.7	4.8	1.5	62	3.9	3.7	1.1	53	3.3	2.6	0.8
—	1200	98	6.2	6.9	2.1	78	4.9	4.9	1.5	65	4.1	3.6	1.1	56	3.5	3.1	0.9
1430	—	112	7.1	8.9	2.7	89	5.6	6.5	2.0	74	4.7	5.0	1.5	64	4.0	3.5	1.1
—	1430	117	7.4	9.5	2.9	93	5.9	6.7	2.0	78	4.9	5.0	1.5	67	4.2	3.7	1.1
1670	—	*	*	*	*	102	6.4	8.8	2.7	85	5.4	6.7	2.0	73	4.6	4.7	1.4
—	1670	*	*	*	*	109	6.9	9.1	2.8	91	5.7	6.8	2.1	78	4.9	5.0	1.5
1825	—	*	*	*	*	114	7.2	10	3.0	95	6.0	8.0	2.4	81	5.1	5.5	1.7
—	1825	*	*	*	*	119	7.5	10.4	3.2	99	6.2	8.3	2.5	85	5.4	5.7	1.7

*Consult factory for recommendations

Table 1. Flow Requirements.

resistance of the boiler plus the entire circulating system at the designated GPM (see Table 1). The temperature rise across the boiler should never exceed 40°F (22°C). Primary-secondary pumping is the most effective way to assure proper flow through the boiler resulting in longer boiler life and greater system efficiency (see Figure 2).

1D. Variable Water Flow Systems

Heating systems using zone valves, zone pumps or 3-way valves can experience reduced water flow through the boiler. This can result in an excessive water temperature rise and unstable boiler operation. If the system water flow is variable, it must not be allowed to fall below 30% of full flow. The boiler must be equipped with staged or modulated fire with the temperature sensor installed in the outlet water. State variable flow when ordering. Laars recommends primary-secondary pumping for all variable flow systems. Primary-secondary pumping is **mandatory** for variable flow systems where minimum flows are less than 30% of full flow conditions. The boiler pump in a primary-secondary system maintains constant flow through the boiler even though the system flow is variable. In a primary-secondary system the pressure drop of the boiler is not added to the system (see Figure 2).

A Special Note About 3-Way Water Valves

3-way water valves (2 position or proportional) are sometimes used to divert water around a boiler and control the temperature of water being supplied to the system. Valves installed in this manner must be supplied with an end switch or some other suitable control to shut off the boiler when the flow is reduced to 30%. The boiler must be supplied with staged or modulated fire as indicated in Section 1D, Variable Water Flow Systems.

It is often possible to accomplish excellent water temperature control without 3-way valves through proper application of staged or modulated firing systems. Consult the factory or local Laars representative for assistance with such systems.

System Pressure Requirements

The model HH and PH boilers are designed to operate on closed, pressurized systems. A minimum of 12 psi should be maintained on the system where boiler supply water temperatures are 200°F (93°C) or less. If higher temperatures are required, the minimum system pressure should be at least 15 psi above the water vapor pressure corresponding to the elevated water temperature.

The hydronic boilers are not suitable for open systems unless the supply water temperatures are kept below 180°F (82°C), and minimum of 5 psi static head is maintained within the boiler.

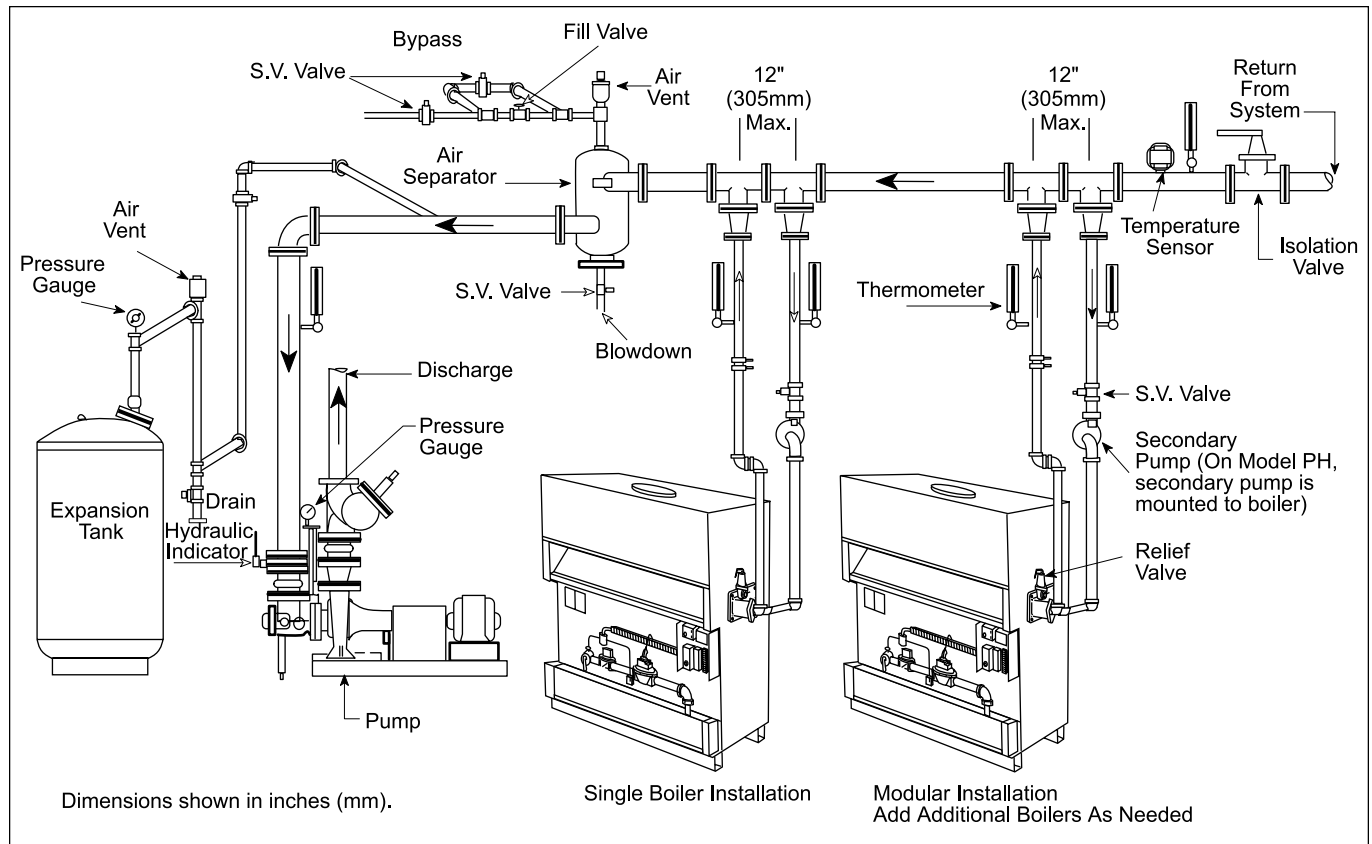

Figure 2. Typical Schematic for a Primary-Secondary System.

1E. Warning Regarding Chilled Water Systems

When a boiler is connected to an air conditioning system where the same water is used for heating and cooling, chilled water must be prevented from entering the boiler. When changing such a system from cooling to heating, the chilled water should be allowed to circulate through the building (after the chiller has been turned off) for a period long

enough for the water to warm up to at least 70°F (21°C) before the water is allowed to flow into the boiler. It is equally important to prevent hot water from entering the chiller. The system shown in Figure 3 is suggested to make sure that the system water is neither too hot nor too cold when a changeover from heating to cooling, or vice versa, takes place. When a boiler is connected to heating coils located in air handling units (where they may be exposed to refrigerated air circulation), the boiler piping system shall be equipped with a flow control valve or other automatic means to prevent gravity circulation of chilled water through the boiler. Chilled water in the boiler will create condensation on the boiler tubes which will drip on the burners and may extinguish the pilot.

Boilers installed in violation of either of the above requirements may void the warranty.

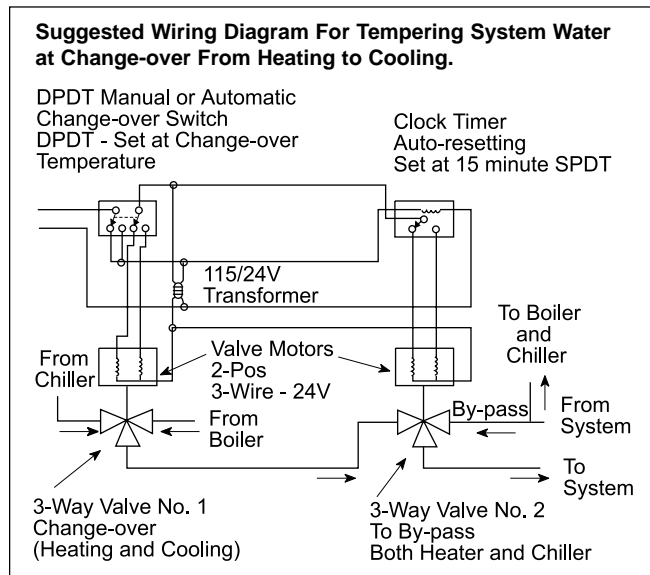

Figure 3. Boiler-Chiller Installation.

1F. Freeze Protection

Boiler installations are not recommended in areas where the danger of freezing exists unless proper precautions are taken for freeze protection. The preferred method of freeze protection is by maintaining a mixture of no more than 50% properly inhibited HVAC glycol. This mixture will protect the boiler to temperatures of about -35°F (-37°C). To get the desired temperature rise across the boiler when this mixture is used, increase the water flow by 15% above the original recommendation. Increase the head loss requirement by 20%.

SECTION 2. Installation

2A. Boiler Placement

The boiler must be placed to provide specific clearances on all sides for maintenance and inspection. There must also be minimum distances maintained from combustible surfaces. These clearances also apply to non-combustible materials, because the boiler requires air circulation for proper operation.

Boiler should be mounted on a level surface. An integral combustible flooring base is provided as standard equipment on all outdoor models. Indoor models can be installed on a combustible floor with a special base assembly which is available from the factory, or with a base that complies with local code requirements. See rating plate for part number of the base assembly.

Do not install boiler on carpeting.

Under the National Fuel Gas Code, ANSI Z223.1, it is permissible to place the boiler on floors other than non-combustible when the installation complies with the American Insurance Code. Figures 5, 6, 7, and 8 show common installation on combustible flooring.

2B. Installation of Indoor Boilers

1. Locate the boiler to provide adequate clearance for inspection and service on all sides (see Table 2). We recommend minimums of 24" from front (for proper access to and service of controls) and 18" at water connection end. For alcove installation, see Figure 9.

Clearance From	Indoor		Outdoor	
	inches	mm	inches	mm
Top	30	762	unobstruct	
Water Conn. Side	12	305	24	610
Opposite Side	6	152	24	610
Front	Alcove		Unobstruct	
Rear	8	203	24	610
Vent Pipe*	6	152	—	
Hot Water Pipes	Per Code		Per Code	

*1" when using type B Vent (refer to Manufacturer's Instructions)

Table 2. Minimum Boiler Clearances From Combustible Surfaces.

2. Install the boiler on a waterproof floor with an adequate floor drain and a 6" (152mm) minimum curb on all four sides to protect the building if boiler repairs are required. ***The manufacturer will not be held liable for any water damage in connection with this boiler.***

2B-1. Combustion Air Supply

1. The boiler location must provide sufficient air supply for proper combustion and ventilation of the surrounding area as outlined in the latest edition of ANSI standard Z223.1 and/or in Canada CAN 1 - B1 49 requirements, and any local codes that may be applicable. Inadequate combustion air supply may result in incomplete combustion, sooting of the heat exchanger, and unsafe operation of the boiler.
2. (a.) In the United States, the general requirements specify that boiler rooms should be provided with two permanent air supply openings communicating directly through the wall to outside air; one within 12 inches (305mm) of the ceiling, and the other within 12 inches (305mm) of the floor. Each opening should have a minimum free area of one square inch per 4,000 BTUH input of the total input rating of all appliances in the enclosed area. See Table 3 for recommended air supply for each model. An improperly ventilated equipment room can get excessively hot and cause accelerated deterioration of controls and electrical components.

Boiler Model	Each Opening*	
	Sq. Inches	Sq. cm
500	125	806.5
600	150	967.8
715	179	1154.9
850	213	1374.3
1010	253	1632.4
1200	300	1935.6
1430	358	2309.8
1670	418	2696.9
1825	457	2948.6

*Net Free Area in Square Inches

Area indicated is for one of two openings; one at floor level and one at the ceiling, so the total net free area could be double the figures indicated. For special conditions refer to the latest edition of ANSI Z223.1.

Consult factory if not communicating directly through the walls with the outdoors.

Note: Check with louver manufacturers for net free area of louvers. Correct for screen resistance to the net free area if a screen is installed. Check all local codes applicable to combustion air.

Table 3. Minimum Recommended Air Supply to Boiler.

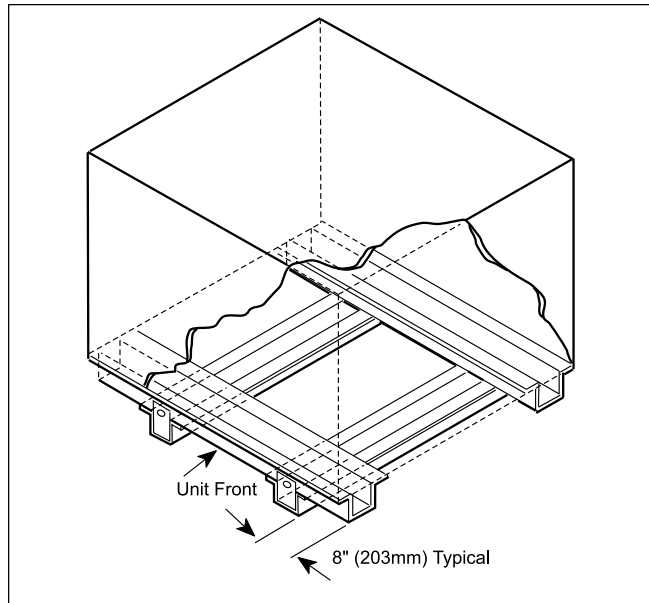

Figure 4. Base for Combustible Floors.

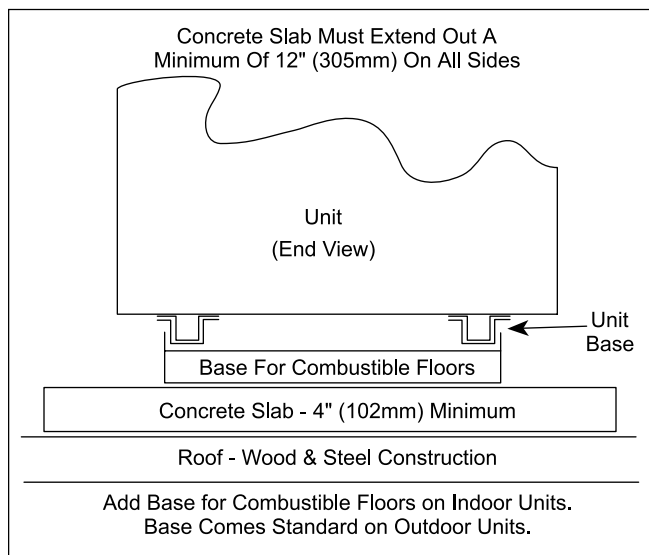

Figure 5. Typical Boiler Installation on Concrete Slab.

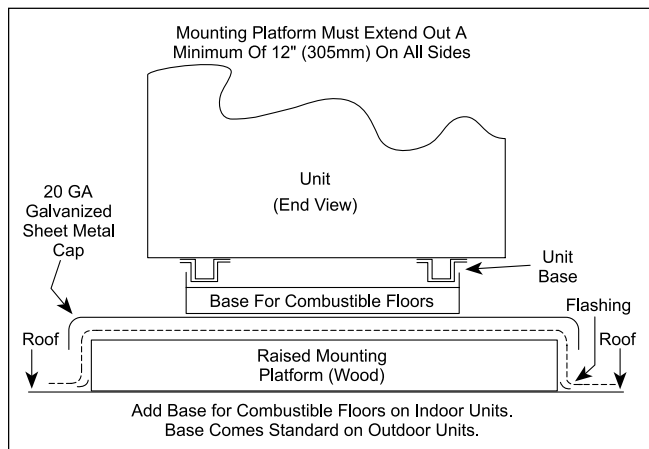

Figure 6. Typical Boiler Installation on Raised Platform (Wood).

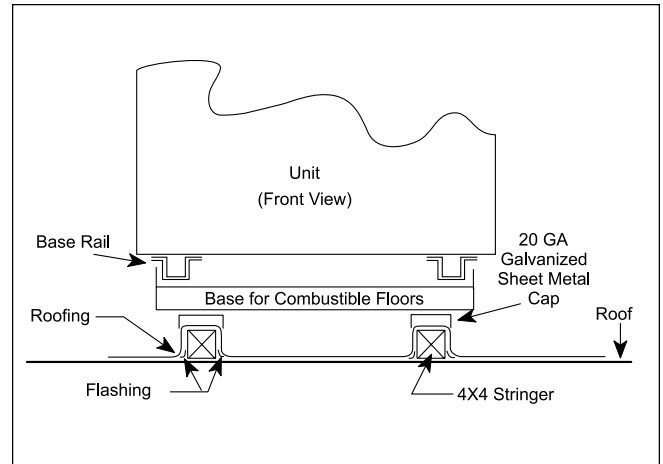

Figure 7. Typical Boiler Installation on Roof Using a 4 x 4 Stringer.

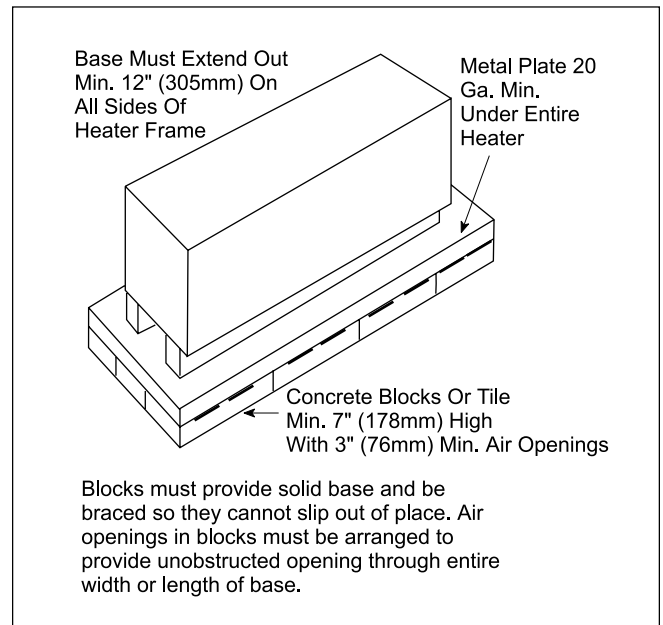

Figure 8. Installation on Concrete Blocks or Tile.

(b.) In Canada, consult local building and safety codes or, in the absence of such requirements, follow CGA requirements and/or CAN 1 - B149 standard. (Table 3 does not apply).

3. Exhaust Fans or Vents: Any equipment which exhausts air from the boiler room can deplete the combustion air supply or reverse the natural draft action of the venting system.

The boiler must be completely isolated and this could cause flue products to accumulate in the room. Additional air must be supplied to compensate for such exhaust. The information in Table 3 is not applicable in installations where exhaust fans or blowers of any type are used. Such installations must be designed by qualified engineers.

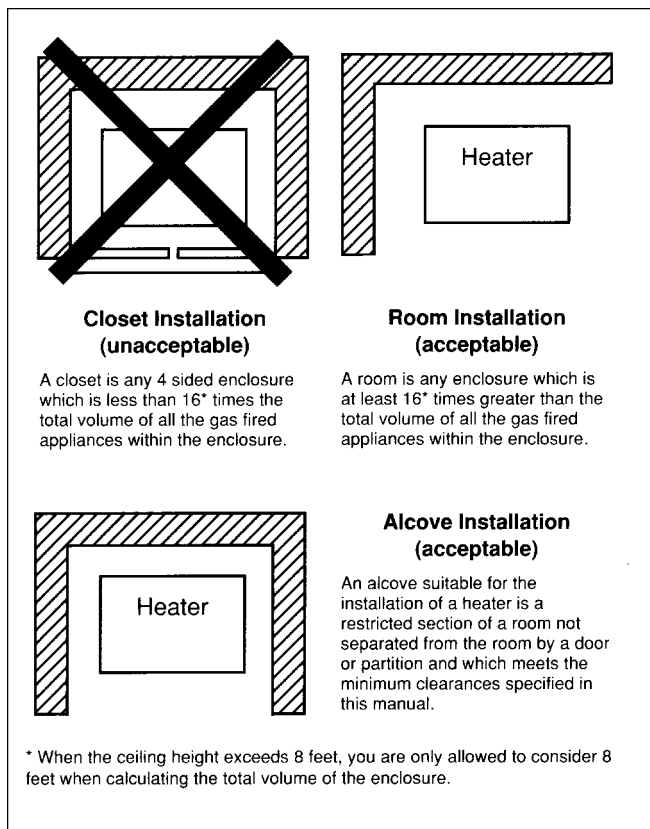

Figure 9. Alcove Installation.

4. If a blower or fan is used to supply air to the heater room, the installer should make sure it does not create drafts which could cause nuisance shutdowns of the pilot. If a blower is necessary to provide adequate combustion air to the boiler, a suitable switch or equivalent must be wired into the boiler control circuit to prevent the boiler from firing unless the blower is operating.
5. The boiler must be completely isolated and protected from any source of corrosive chemical fumes such as trichlorethylene, perchlorethylene, chlorine, etc.

2B-2. Venting

1. Laars boilers have built-in draft diverters for natural draft operation and must not be connected to any portion of a mechanical draft system under positive pressure. The flue outlet must be connected to a clear, unobstructed vent of adequate capacity ending above the highest point of the building with an approved vent cap. The venting system should be installed according to the latest edition of ANSI Z223.1 and/or, in Canada, CAN1-13149 requirement and any local codes having jurisdiction.

IMPORTANT NOTE: Do not use sheet metal screws at the snap lock joints of Type B gas vents.

2. Do not weld or fasten the vent pipe to the boiler draft hood. The weight of the stack must not rest on the boiler. The draft hood and boiler top must be easily removable for normal boiler service and inspection.
3. Avoid using long horizontal runs of the vent pipe, and too many 90° elbows, reductions or restrictions. Horizontal runs should have at least a 1/4" rise per foot in the direction of flow. A vent connector should be supported for the design and weight of the material used to maintain clearances and prevent physical damage and separation of joints.
4. Avoid ending heater vents near air conditioning or air supply fans. The fans can pick up exhaust flue products from the boiler and return them inside the building, creating a possible health hazard. A minimum of 4 feet (1.2m) horizontal distance must be maintained from electrical meters, gas meters, and relief equipment.
5. Always use double-wall or insulated vent pipe (Type B or equivalent). In cold weather, uninsulated outside vents can chill the rising flue products, blocking the natural draft action of the venting system. This can create a health hazard by spilling flue products into the boiler room.
6. Avoid oversize vent piping or extremely long runs of the pipe which may cause excessive cooling and condensation. Rule of Thumb: The total length of the vent, including the connector and any offset, should not exceed 15 feet (4.6m) for every inch of vent diameter. Longer total lengths shown in venting tables are based on maximum capacity, not condensation factors.
7. When the installation of a draft fan is necessary in connecting a venting system to a Laars boiler, the installation should be engineered by competent personnel following good engineering practices. The draft fan supplier should be consulted for correct size. The installation should be in accordance with the latest edition of ANSI Z223.1 and/or, in Canada, CAN 1-B149 requirement and any local codes having jurisdiction. When a draft fan is installed, a suitable draft switch must be wired into the boiler control circuit at terminal designated "Field Interlock" to prevent firing of the boiler unless a positive draft has been established.
8. When an existing boiler is removed from a common venting system, the common venting system is likely to be too large for proper venting of the appliances remaining connected to it. At the time of removal of an existing boiler, the following steps shall be followed with each appliance remaining connected to the common venting system placed in operation, while the

other appliances remaining connected to the common venting system are not in operation.

- (a) Seal any unused openings in the common venting system.
- (b) Visually inspect the venting system for proper size and horizontal pitch and determine there is no blockage or restriction, leakage, corrosion and other deficiencies which could cause an unsafe condition.
- (c) Insofar as is practical, close all building doors and windows and all doors between the space in which the appliances remaining connected to the common venting system are located and other spaces of the building. Turn on clothes dryers and any appliance not connected to the common venting system. Turn on any exhaust fans, such as range hoods and bathroom exhausts, so they will operate at maximum speed. Do not operate a summer exhaust fan. Close fireplace dampers.
- (d) Place in operation the appliance being inspected. Follow the lighting instructions. Adjust thermostat so appliance will operate continuously.
- (e) Test for spillage at the draft hood relief opening after 5 minutes of main burner operation. Use the flame of a match or candle, or smoke from a cigarette, cigar or pipe.
- (f) After it has been determined that each appliance remaining connected to the common venting system properly vents when tested as outlined above, return doors, windows, exhaust fans, fireplace dampers and any other gasburning appliance to their previous conditions of use.
- (g) Any improper operation of the common venting system should be corrected so the installation conforms with the latest edition of the National Fuel Gas Code, ANSI Z223.1. When resizing any portion of the common venting system, the common venting system should be resized to approach the minimum size as determined using the appropriate tables in Appendix G in the National Fuel Gas Code, ANSI Z223.1.

2C. Installation of Outdoor Boilers

1. Locate the boiler to provide the minimum clearances as listed in Table 2, "Boiler Clearances." See *Service Clearance, 2 B.1.*
2. Do not place the boiler in an enclosure or wall recess. Avoid locations where wind deflection

off structures might cause a down draft. When such wind conditions are possible, place the boiler at least three (3) feet (0.9m) from the structures.

3. Never install the boiler under any kind of roof overhang. Do not place the boiler below or adjacent to any doors, windows, louvers, grills, etc. which connect in any way with an inhabited area of a building. This includes other structures such as garages or utility rooms (see Figure 10).

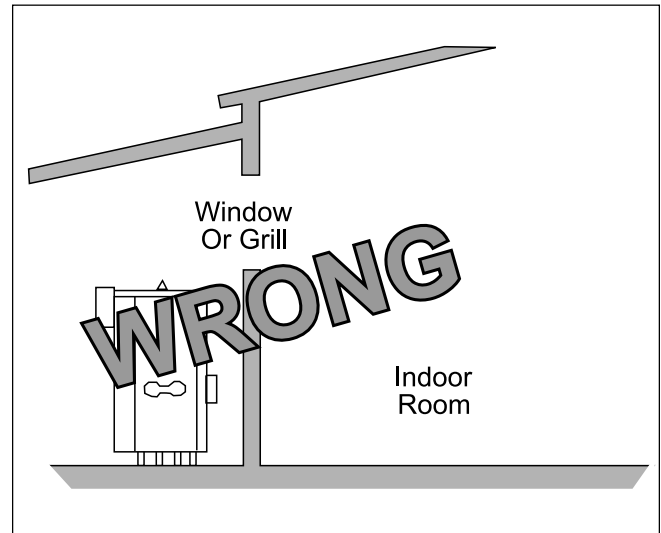

Figure 10. Incorrect Outdoor Installation.

4. Although these models are AGA designed certified for outdoor installations, such installations are not recommended in areas where the danger of freezing exists unless proper precautions are taken for freeze protection.

⚠ Caution

Outdoor installations are not recommended in areas where the danger of snow blockage exists.

2D. Gas Supply and Piping

Review the following instructions before proceeding with the installation.

1. Verify that the boiler is fitted for the proper type of gas by checking the rating plate. Laars boilers are normally equipped to operate below a 2000 foot (610m) altitude. Boilers equipped to operate at higher altitudes have appropriate stickers or tags attached.
2. Use the figures in Table 4 to provide adequate gas piping from the gas meter to the boiler.
3. A trap (drip leg) must be provided ahead of the gas controls (see Figure 11). A manual gas

Size	Distance from Gas Meter or Last Stage Regulator		
	0-100' (0-30.5m)	100-200' (30.5-61m)	200-300' (61-91.4m)
500	1-1/2"	2"	2"
600	1-1/2"	2"	2-1/2"
715	2"	2"	2-1/2"
850	2"	2-1/2"	2-1/2"
1010	2"	2-1/2"	3"
1200	2-1/2"	3"	3"
1430	2-1/2"	3"	3"
1670	2-1/2"	3"	3"
1825	2-1/2"	3"	3-1/2"

Note: These figures are for Natural Gas (.65 Sp. Gr.), and are based on 1/2" water column pressure drop. Check supply pressure with a manometer, and local code requirements for variations. **For LPG**, reduce pipe diameter one size, but maintain a 1" minimum diameter. A normal number of Tees and elbows have been taken into allowance.

Table 4. Gas Piping Sizes.

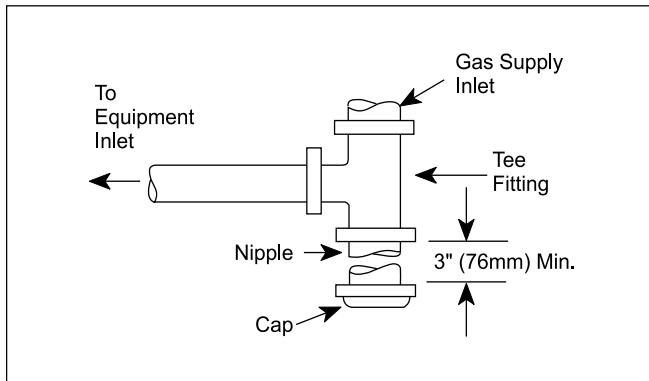

Figure 11. T-Fitting Sediment Trap Installation.

shutoff valve must also be provided for service convenience and safety. Check the local codes.

- The boiler and its individual shutoff valve must be disconnected from the gas supply piping system during any pressure testing of that system at test pressures in excess of 1/2 psig. The boiler must be isolated from the gas supply piping system by closing its individual manual gas shutoff valve during any pressure testing of the gas supply piping system at test pressures equal to or less than 1/2 psig.
- Provide gas supply pressure to the boiler as follows:

	Natural Gas	LPG
Min. (inches water column)	Per Rating Plate	
Max. (inches water column)	9	14

Note: The boiler and all other gas appliances sharing the boiler gas supply line must be firing at maximum capacity to properly measure the inlet

supply pressure. Low gas pressure could be an indication of an undersized gas meter and/or obstructed gas supply line.

- The correct burner manifold gas pressure is stamped on the rating plate. The regulator is preset at the factory and normally requires no further adjustment.
- The gas manifold and control assembly was tested and conform to the safe lighting and other performance criteria specified in the latest editions of ANSI Z21.13 and CGA 3.3 Low Pressure Boiler Standard.
- Before operating the boiler, the complete gas supply system and all connections must be tested for leaks using a soap solution. **Do not use raw flame.**

⚠ Caution

Since some leak test solutions (including soap and water) may cause corrosion or stress cracking, the piping must be rinsed with water after testing, unless it has been determined that the leak test solution is noncorrosive.

2E. Electrical Wiring

Electrical diagrams are included with the packet provided with each unit.

⚠ WARNING

The boiler must be electrically grounded in accordance with the most recent edition of the National Electrical Code, ANSI/NFPA 70. In Canada, all electrical wiring to the boiler should be in accordance with the Canadian Electrical Code, CSA C22.1 Part 1. Do not rely on the gas or water piping to ground the metal parts of the heater. Frequently, plastic pipe or dielectric unions isolate the boiler electrically. Service and maintenance personnel who work on or around the boiler may be standing on wet floors and could be electrocuted by an underground boiler.

- Check boiler wiring and pump for correct voltage, frequency and phase. If the pump circuit is other than 115V, check to see that the boiler is provided with an appropriate transformer.
- Wire the boiler and pump exactly as shown in the wiring diagram supplied with the boiler.

3. The pump and boiler must be electrically interlocked so the boiler cannot come on unless the pump is running.
4. All field installed electrical safety devices and all field installed devices (draft switches, relays, timers, outdoor temperature reset devices, etc.) can be connected to the heater wiring at points shown in the wiring diagram designated "Field Interlock."

2F. Water Piping of System

1. Be sure to provide valves at the inlet and outlet of the boiler so it can be readily isolated for service. A butterfly or similar type of valve is recommended.
2. The pressure relief valve installed in the tapped opening provided in the outlet header (See Figure 12), must be piped, but not fastened, to a drain or floor sink. The drain pipe must be the same size as the valve outlet and must pitch downward from the valve.

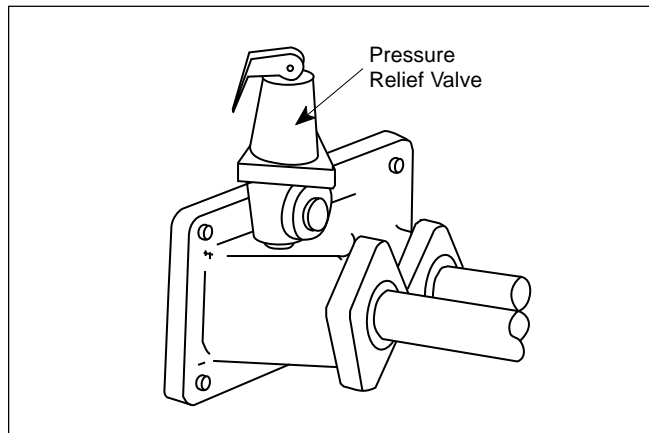

Figure 12. Pressure Relief Valve Location.

Special attention must be given to relief valve settings in installations where the boiler is located on the ground floor of a tall building. The static pressure of the system is elevated and could cause the relief valve to leak. Where no special setting of the relief valve is ordered, the factory will furnish a 75 psi setting. Never reduce the relief valve openings.

3. Pressure relief valve lever must be tripped at least once a year to insure that waterways are clean. When manually operating lever, water will discharge through drain line. Precautions must be taken to avoid contact with hot water and water damage.
4. The weight of all water and gas piping should be supported by suitable hangers or floor stands.

5. Check piping diagrams with local applicable plumbing, heating and building safety codes.
6. A boiler installed above radiation level must be provided with a low water cutoff device either as part of the boiler or at the time of boiler installation.
7. Install manual and/or automatic bleeding devices at high points in the system to eliminate air. Install a correctly sized air charger and tank drainer, as appropriate.

2G. Filling Fully-Connected System

1. Close all bleeding devices and open make-up water valve. Allow system to fill slowly.
2. If make-up water pump is employed, adjust pressure switch on pumping system to provide a minimum of 12 psi at the highest point in the heating loop.
3. If a water pressure regulator is provided on the make-up water line, adjust the pressure regulator to provide at least 12 psi at the highest point in the heating loop.
4. Open bleeding devices on all radiation units at the highest points in the piping throughout the system, unless automatic air bleeders are provided at such points.
5. Run system circulating pump for a minimum of 30 minutes with the boiler shut off.
6. Open all strainers in the circulating system and check for debris.
7. Recheck all air bleeders as described in Step 4 above.
8. Check liquid level in expansion tank. With the system full of water and under normal operating pressure, the level of water in the expansion tank should not exceed 1/4 of the total, with the balance filled with air.
9. Start up boiler according to procedure described in Section 3B. Operate the entire system, including the pump, boiler, and radiation units for one (1) hour.
10. Recheck the water level in the expansion tank. If the water level exceeds 1/4 of the volume of the expansion tank, open the tank drainer and drain to that level.
11. Shut down the entire system and vent all radiation units and high points in the system piping as described in Step 4 above.
12. Close make-up water valve and check strainer in pressure reducing valve for sediment or debris from the make-up water line. Reopen make-up water valve.

13. Check gauge for correct water pressure and also check water level in system. If the height indicated above the boiler insures that water is at the highest point in the circulating loop, then the system is ready for operation.
14. Within three (3) days of start-up, recheck all air bleeders and expansion tank as described in Steps 4 and 8 above.

SECTION 3. Operation

3A. Controls - General

1. Electronic Ignition Controls:
 - a. Intermittent Ignition:

Pilots are automatically lit when the operating aquastat calls for heat (System #4 and #9) The unit performs its own safety check and opens the main valves only after the pilot is proven to be lit. Whenever the pilot flame is interrupted, the main gas valve closes within 0.8 seconds.
 - b. Electronically Supervised Standing Pilot System (System #16):

When pilot flame fails, the ignition control module responds in less than 0.8 seconds and provides 100% safety shutdown.

2. Operating Controls:
 - a. Electrically Operating Controls:

Single, two-stage, four-stage or modulating aquastats are provided in models HH and PH boilers to control the desired service water temperature. The temperature sensing bulb is located in the boiler inlet.
 - b. Modu-Snap Valves (Mechanical Modulation Only):

These valves are furnished in addition to the main electric gas valve. Each valve has a remote capillary bulb immersed in a well at the outlet header to maintain a constant outlet temperature. Consult Table 5 for desired temperature setting.

Dial No.	1	2	3	4	5	6	7	8	9
Temp °F	120	135	150	165	180	195	210	225	240
Temp °C	49	57	66	74	82	91	99	107	116

Table 5. Modu-Snap Temperature Settings

3. High Limit Controls:

The manual reset high limit switches are provided as standard equipment on all boilers. Automatic reset switches are optionally provided. The temperature sensing bulb of the switch is always located in the boiler outlet. Burners will automatically shut down whenever overheating of water occurs.

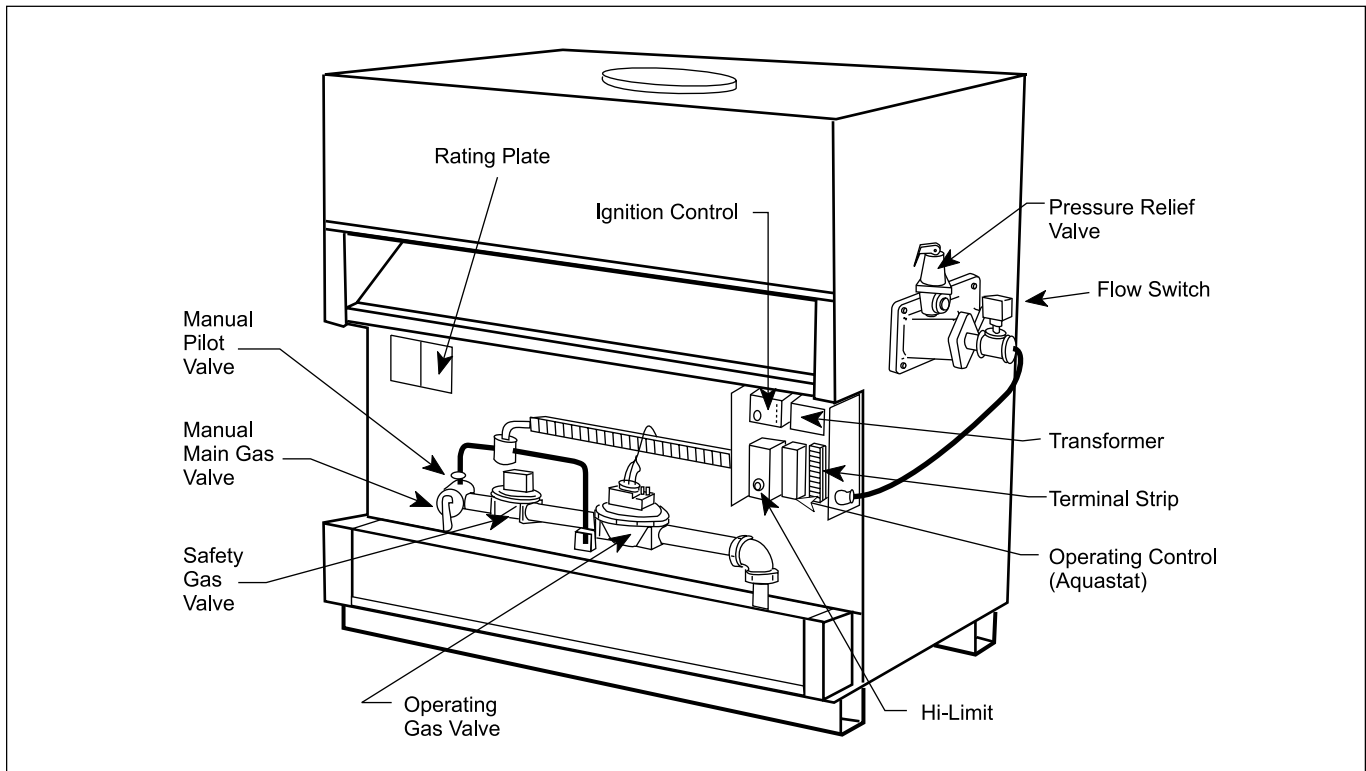

Figure 13. Typical Controls Locations.

4. Flow Switch:

Standard on all models: Models HH and PH, the switch is mounted in the outlet “tee” connection. The flow switch shuts down all burners in case of pump failure.

5. Low Water Cut Off (Optional):

The low water cut off automatically shuts off boiler whenever water level drops below probe. Located at boiler inlet (model PH) and at return header (model HH).

3B. Initial Start-Up

Lighting: Safe lighting and other performance criteria were met with the gas manifold and control assembly provided on the boiler when it underwent tests specified in the ANSI Z21.13 standard.

Before placing the boiler in operation, be certain that the boiler is filled with water and all air is purged from the system. Once the boiler is connected to the gas supply, the automatic safety shutoff devices must be checked.

1. Before beginning the tests, make sure the main manual gas valve, and any other boiler firing valves are in the “OFF” position.
2. Make sure the boiler’s power switch is in the “ON” position. After placing the manual pilot gas valve in the open position and resetting all safety devices, (high limit, pressure switch, low-water cutoff, etc.) pilot(s) can be lit following the procedure located on the boiler rating plate.
3. Once the pilot(s) is lit and has been established for five minutes, the flame failure response time should be checked as follows:

Systems 9 and 4 - (Intermittent ignition), natural gas only: With this system pilots are automatically lit when the operating controls call for heat. If the pilot flame fails for any reason, the main valve is shut off within one second and the pilot spark ignition is initiated until the pilot flame has been reestablished. On propane systems, unit locks out for safety. This sequence should be checked by turning off the manual pilot gas valve, and, at the same time, monitoring the audible sparking at the pilot burner and signal interruption to the main valve.

⚠ Caution

Propane gas is heavier than air and sinks to the ground. Exercise extreme care in lighting the boiler when so equipped.

System 16 - (Electronically supervised standing pilot system): Extinguish the pilot flame by placing the manual pilot valve in the closed position, and at the same time, begin recording the time it takes for the output signal from the electronic ignition control to be

interrupted. The signal interruption can be detected either with a test light or a voltmeter. The response time should never exceed one second.

4. With the pilots lit, initial activation of the main burners can be achieved by slowly opening the main valve. The result should be a smooth lighting of the main burners.

Hi-Limit Checkout :

After running the boiler for a long enough period, bring the water temperature within the range of the hi-limit and slowly back off the high limit setting until the boiler shuts off. The main burners should reignite when the hi-limit is reset and turned back up to its original setting. The boiler should now run until it shuts off automatically on operating aquastat.

3C. To Start Up System:

1. Start Up Boiler

Be certain system pump is running, then proceed as follows:

- a. Turn off main electrical switch.
- b. Turn off all manual gas valves and wait five minutes (see Figure 14).
- c. Set operating control to lowest setting.
- d. Slowly turn manual gas valve to “ON”.
- e. Reset all safety valve switches (manual reset high limit and low water cut off).

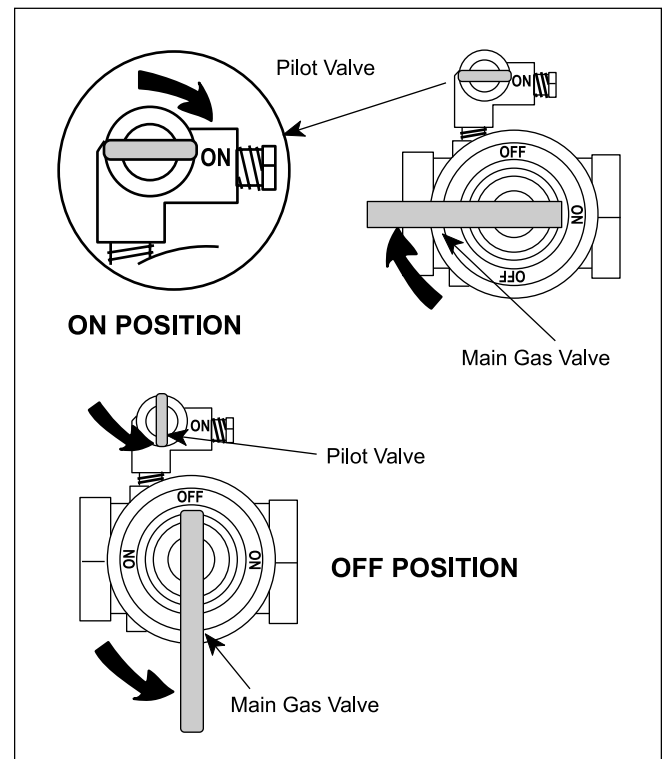

Figure 14. Gas Manual Valves.

- f. Open manual pilot valve. Turn on main electrical switch.
- g. Set temperature controller to desired temperature. Pilot will light automatically to ignite main burners whenever the aquastat calls for heat.
- h. For standing pilot system, press on pilot relay knob (see Figure 15), light pilot and keep relay knob depressed for one minute then release. Once the pilot is lit, the power is supplied through the aquastat to the main gas valve.

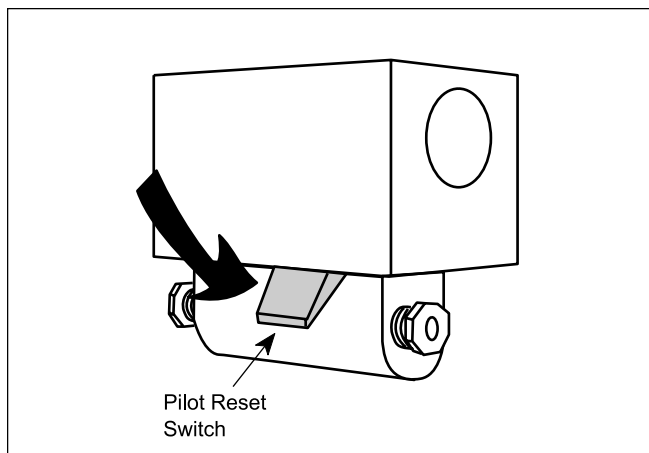

Figure 15. Pilot Safety Relay.

2. To set the temperature and high-limit controls:
 - a. Set the temperature controller at the system design temperature.
 - b. Set the high-limit to 40-50°F above temperature controller setting.
 - c. **Models with Mechanical Modulation**
Set the temperature controller (Modu-Snap valve) dial to the desired water temperature (see Table 5).
3. Minimum input rates:
The low firing rate setting must be equal to or greater than the specified minimum input rating as shown on the appliance rating plate. Laars' boilers use gas valves which are factory set to provide an input on low fire that meet or exceed the specified minimum.

3D. To Turn Off Boiler:

1. Turn off main electric switch.
2. Close all manual gas valves.

3E. To Shut Down System:

To shut down boiler, turn off all manual gas valves and electrical disconnect switches. Whenever danger of freezing exists, shut off water supply and

remove drain plug in the bottom of front header cover. Drain every part of system subject to freezing temperature.

SECTION 4. Maintenance

1. Lubricate the water circulating pump (see instructions found on the pump).
2. If a strainer is employed in a pressure reducing valve or in piping, clean it every six (6) months.
3. At start-up and every six (6) months thereafter, the pilot and main burner flame should be observed for proper performance (see Figure 16). See attached lighting and shut-down instructions for proper pilot flame pattern). If flame has the appearance of "sooting" tips, check for debris near orifices. Call serviceperson.

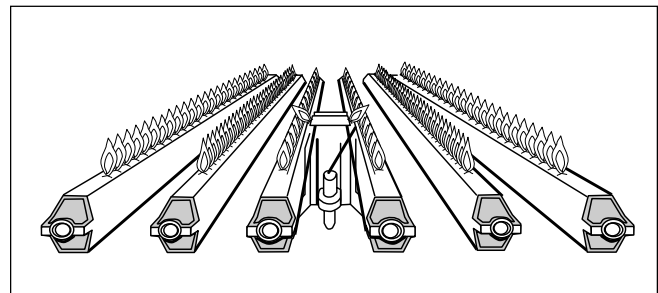

Figure 16. Main Burner Flame Pattern.

4. Inspect the venting system for obstruction, leakage and corrosion at least once each year.
5. Keep boiler area clear and free from combustible material, gasoline and other flammable vapors and liquids (see Table 2 for minimum clearances).
6. Be certain all combustion air and ventilation openings are unobstructed.
7. Check for fouling on the external surfaces of the heat exchanger every six months. (**NOTE:** After installation and first start-up, check the heat exchanger for fouling after the following periods of operation: 24 hours, 7 days, 30 days, 90 days, and once every six months thereafter).

Fouling on the external surfaces of the heat exchanger is caused by incomplete combustion and is a sign of combustion air and/or venting problems. As soon as any fouling is observed, the cause of the fouling should be corrected (see **Section 5, Troubleshooting Guide**). The heat exchanger can be checked by locating a mirror under the burners with a flashlight. An alternate method is to remove the venting and top panel as necessary to inspect from above. Also check the vent system for defects at this time.

- a. If cleaning is required, shut off all electrical and gas supply to the heater.
- b. To expose the heat exchanger:

Indoor Models:

Remove flue pipe, top of unit, rear upper jacket, flue collector rear panel and heat exchanger baffles.

Outdoor Models:

Remove vent top assembly, rear upper jacket, flue collector rear panel and heat exchanger baffles.

- c. Remove all burners:

It is usually more convenient to remove the burner tray assembly. Disconnect sensor wire, ignition cable (or thermocouple generator) and pilot gas line. Disconnect manifold inlet union(s). Remove the four (4) retaining screws. Grasp burner/pilot assembly firmly at the front. Push it back, disengaging it from the gas orifice. Lower the front of the burner (to avoid damaging pilot shield) then remove the burner tray.

Caution

Black carbon or green soot on a dirty heat exchanger can, under certain conditions, be ignited by a random spark or open flame. To prevent this unlikely occurrence, dampen the soot deposits with wet brush or fine water spray before servicing or cleaning the heat exchanger.

With a wire brush, remove soot and loose scale from heat exchanger. Clean fallen debris from bottom of heater. Make sure burner ports are clear and pilot assembly is free of debris.

- d. Reassemble in reverse order: Be sure the heat exchanger baffles are replaced.
8. The gas and electric controls installed on boilers are engineered for both dependable operation and long life, but the safety of this equipment completely depends on their proper functioning. It is strongly recommended that the basic items be checked by a competent serviceperson every year and replaced when necessary. The basic controls are:
 - a. Water temperature controls.
 - b. Pilot safety system.
 - c. Automatic electric gas valve(s).
 - d. Flow sensing safety device.
 9. Low water cutoffs should be inspected every six (6) months, including flushing of float types.

NOTE: Warranty does not cover any damage caused by lack of required maintenance or improper operating practices.
 10. Both modulating and stage valve are adjusted at the factory for minimum permissible rates and should not be readjusted.

SECTION 5.

Troubleshooting and Analysis of Service Problems

1. For proper service and problem diagnosis of the heater and heater system, the following tools are required:
 - a. Gas pressure test kit with range from zero to 14 W.C. Either a slack tub manometer or an accurate gas pressure gauge is acceptable with proper adapters which will connect to the available fittings in the line and on the gas valve.
 - b. Multi-meter with the following ranges:
0 to 500 volts A.C.
0 to 1000 ohms continuity.
 - c. Tube cleaning kit consisting of reamer, stainless steel brush, speed handle and handle extensions.
 - d. Strap on digital temperature gauge to check temperature rise.
2. In addition, the boiler should be equipped with a system pressure gauge with proper ranges for boiler operation.

3. BOILER WILL NOT FIRE.

Possible Cause	What To Do
A. Electric power is off.	A. Check to see that main power switch is "ON." Use testing device to trace power to boiler junction box.
B. Operating or safety control has opened circuit to electric gas valve.	B. Turn off power. Use continuity across terminals of each operating and safety control switch up to the electric gas valve. Replace defective control.
C. Pilot flame is out.	C. Relight pilot per instruction.
D. Manual reset device has tripped.	D. Follow instructions for start-up. Reset Pilot safety and all manual reset safety switches and reset manual safety gas valve.
E. No gas pressure to burners.	E. Trace gas line to service shutoff cock. If service cock is open, trace gas line to meter. If no pressure is present at meter, call for public utility service. If gas is present in boiler inlet, check pressures in following sequence: (1) downstream from pressure regulator; (2) downstream from electric gas valve. Replace or adjust as necessary.
F. Electric gas valve operator is burned out or shortened.	F. Disconnect wiring harness at gas valve terminals. Check continuity to actuator coil. If open circuit or short is indicated, replace coil or operator.

4. PRESSURE RELIEF VALVES LEAKING INTERMITTENTLY OR STEADILY.

Possible Cause	What To Do
A. Static pressure in system exceeds setting of relief valve.	A. Calculate height of water in system above boiler. Install new valve with psi setting 25% above required static system working pressure. Do not exceed 160 psi.
B. Expansion tank is waterlogged (if installed).	B. Drain expansion tank, then reopen it to the system. Look for leaks in expansion tank or fittings. Calculate required volume of expansion tank in relation to system to determine that tank is adequate.

5. BOILER IS POUNDING, KNOCKING OR EMITTING STEAM FROM RELIEF VALVES.

Possible Cause	What To Do
A. Low or no water flow.	A. This condition is usually caused by lack of adequate flow through boiler. Check the following: (1) Is the boiler wired into the pump circuit so that the boiler cannot fire unless the pump is running? (2) Check to see that all valves in system are open to be sure that water can circulate through the boiler and the system. (3) If the system has automatic water valves (2-way or 3-way) that can cut off the water flow through the boiler check to see that they are equipped with end-switches which shut the boiler down when the water flow through the boiler is reduced by 70% from full flow. (4) Examine pump for clogged impeller.
B. Low or no system pressure.	B. Clean strainer in pressure reducing valve. Look for closed valve water line or a leak in the system.
C. Clogged "Y" strainer.	C. Remove strainer element and clean screen.
D. Debris from system piping is blocking tubes.	D. Remove header covers. Examine all tubes and waterways. Use new gaskets when reassembling. Clean out tubes.
E. Scale has formed in tubes.	E. This is always caused by the inflow of raw water into the system. Clean tubes with tube cleaning kit. Determine hardness. Check for modified flow if necessary.

6. SOOT IN FLUEWAYS OR IN TUBES, OR NOXIOUS FUMES INDICATIVE OF BAD COMBUSTION.

Possible Cause	What To Do
A. Combustion air supply to boiler room is inadequate.	A. Check air supply opening. Look for debris in screen or louvre which covers combustion air opening, or for material blocking the opening.
B. Stack or vent is blocked or restrictive.	B. Look for blocked stack and excessive number of elbows in stack or excessive length of horizontal runs.
C. Severe down draft is causing spillage of flue products into room.	C. Check for (1) proper vent cap on stack; (2) adequate height of stack above roof; (3) equipment exhausting air from inside of building; and (4) proper installation of draft diverter.
D. Gas pressure to burners is excessive.	D. Check gas pressure with Manometer, and adjust with heater firing at full rate.
E. Boiler not fitted for the fuel being supplied.	E. See nameplate for correct fuel.
F. Boiler installed at high altitude without proper derating.	F. Installations at altitudes in excess of 2000 ft. above sea level are subject to jurisdiction of the local inspection authorities.

7. WATER DRIPPING IN FIREBOX.

Possible Cause	What To Do
Tub in heat exchanger has overheated and ruptured.	A tube failure is almost always caused by (1) scale formation in the tube or (2) inadequate water flow through the boiler.

SECTION 6. Parts Descriptions and Order Numbers

Key No	Description	Model 500	Model 600	Model 715	Model 850	Model 1010	Model 1200	Model 1430	Model 1670	Model 1825
1	Top Panel Assembly	10535701	10535702	10535703	10535704	10535705	10535706	10535707	10535708	10535709
2	Spacer, Flue Collector				10540800	10540800	10540800	10540800	10540800	10540800
3	End Panel, Flue Collector (left)	10533700	10533700	10533700	10533700	10533700	10533700	10533700	10533700	10533700
4	End Panel, Flue Collector (right)	10533800	10533800	10533800	10533800	10533800	10533800	10533800	10533800	10533800
5	Rear Panel, Flue Collector	10535501	10535502	10535503	10535504	10535505	10535506	10535507	10535508	10535509
6	Rear Panel, Ext., Flue Collector	Not Required								
7	Front Support, Flue Collector	10534401	10534402	10534403	10534404	10534405	10534406	10534407	10534408	10534409
8	Tile Cover, Front & Rear	10534201	10534202	10534203	10534204	10534205	10534206	10534207	10534208	10534209
9	Baffle, Heat Exch. (Ft & Rear)	10534301	10534302	10534303	10534304	10534305	10534306	10534307	10534308	10534309
10,11	Baffle, Heat Exchanger	10534601	10534602	10534603	10534604	10534605	10534606	10534607	10534608	10534601
		(7)	(14)	(14)	(14)	(14)	(28)	(28)	(28)	(14)
										10534602
										(14)
12	Return Header (S-00981)	10364300	10364300	10364300	10364300	10364300	10364300	10364300	10364300	10364300
	Return Header (S00642)									
	Bronze	10364301	10364301	10364301	10364301	10364301	10364301	10364301	10364301	10364301
13	Inlet/Outlet Header (S-00943)	10364500	10364500	10364500	10364500	10364500	10364500	10364500	10364500	10364500
	Inlet/Outlet Header (S00640)	10364501	10364501	10364501	10364501	10364501	10364501	10364501	10364501	10364501
	Bronze									
14	Flange, 2" (S00636)	10391302	10391302	10391302	10391302					
	Flange, 2 1/2" (S00635)					10391303	10391303	10391303	10391303	10391303
	Flange, 2 1/2" (S00644), Bronze	10391304	10391304	10391304	10391304	10391304	10391304	10391304	10391304	10391304
15	Flange Gasket	S0063700	S0063700	S0063700	S0063700	S0063700	S0063700	S0063700	S0063700	S0063700
16	Header Gasket w/Barrier	S0095100	S0095100	S0095100	S0095100	S0095100	S0095100	S0095100	S0095100	S0095100
17	Header Gasket	Use S00951 00-Cut Out Barrier								
18	Baffle, Water Inlet	10338300	10338300	10338300	10338300	10338300	10338300	10338300	10338300	10338300
19	Barrier, Water	10397500	10397500	10397500	10397500	10397500	10397500	10397500	10397500	10397500
20	Well, Aquastat	E0025900	E0025900	E0025900	E0025900	E0025900	E0025900	E0025900	E0025900	E0025900
	Well, Aquastat F/4 Stage	E0085700	E0085700	E0085700	E0085700	E0085700	E0085700	E0085700	E0085700	E0085700

NOTE: Numbers in () represent quantity required for each size. Quantity is one otherwise.

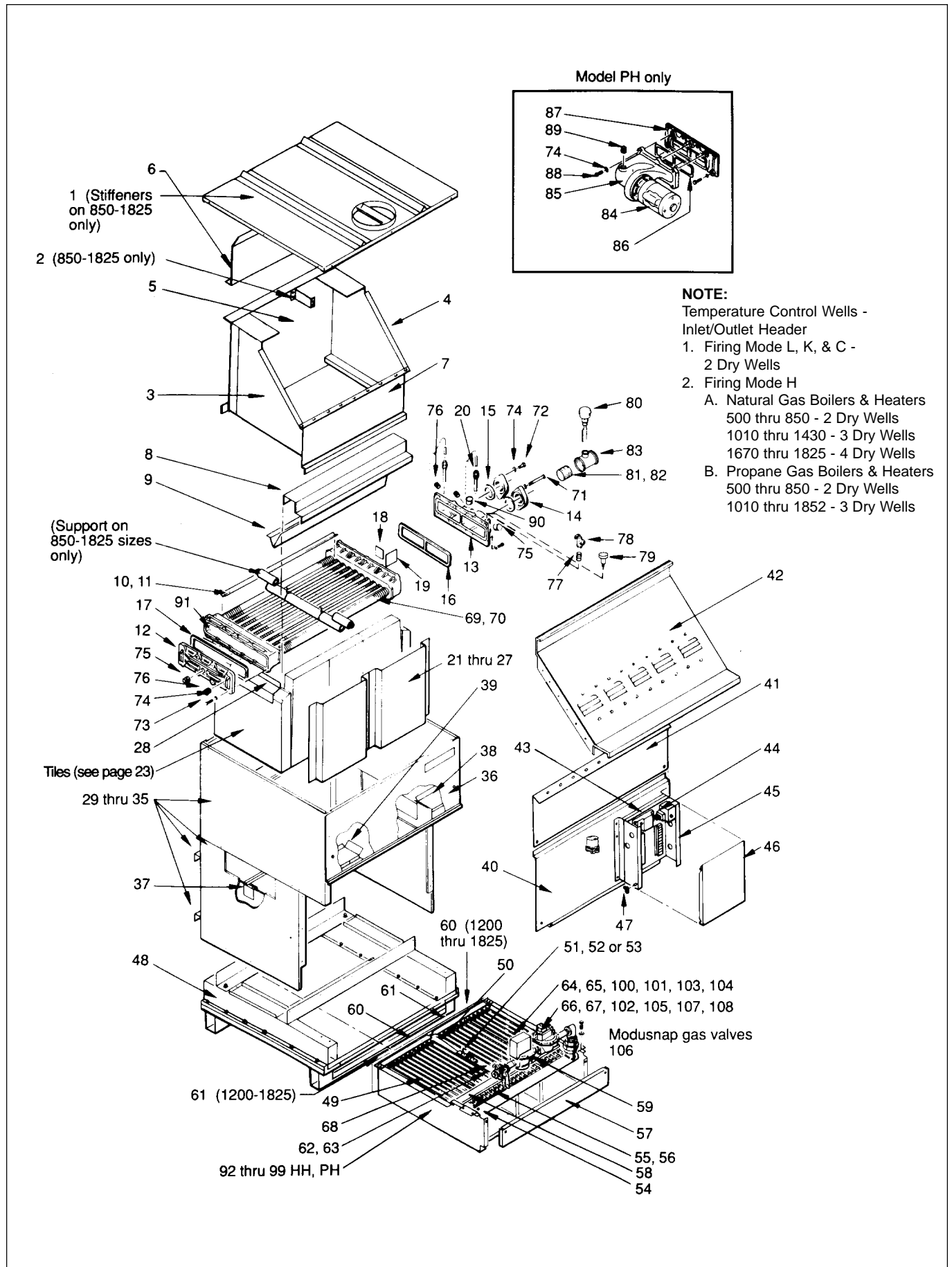

Figure 19. Parts Identification.

Key Description No	Model 500	Model 600	Model 715	Model 850	Model 1010	Model 1200	Model 1430	Model 1670	Model 1825
21 Tile, Heat Shield/Spcr, Frt. & Rr.	10560100 (2)	—	—	—	—	—	—	—	—
22 Tile, Heat Shield/Spacer, Front	—	10547901	10547902	—	—	10547903	10547901	10547904	10547903
23 Tile, Heat Shield/Spacer, Front	—	—	—	10548002	10548003	—	—	—	10548001
24 Tile, Heat Shield/Spacer, Front	—	—	—	—	—	10548101	10548102	10548103	10548104
25 Tile, Heat Shield/Spacer, Rear	—	10548201	10548202	—	—	10548203	10548201	10548204	10548203
26 Tile, Heat Shield/Spacer, Rear	—	—	—	10548302	10548303	—	—	—	10548301
27 Tile, Heat Shield/Spacer, Rear	—	—	—	—	—	10548401	10548402	10548403	10548404
28 Saddle Assembly, End Tile	10533600 (2)	10533600 (2)	10533600 (2)	10533600 (2)	10533600 (2)	10533600 (2)	10533600 (2)	10533600 (2)	10533600 (2)
29 Lower End Panel/Heat Shield Weldment, Right	10540701	10540701	10540701	10540701	10540701	10540701	10540701	10540701	10540701
30 Lower End Panel/Heat Shield Weldment, Left	10540702	10540702	10540702	10540702	10540702	10540702	10540702	10540702	10540702
31 Lower Rear Panel & Baffle Rear Weldment	10532901	10532902	10532903	10532904	10532905	10532906	10532907	10532908	10532909
32 Middle Rear Panel/Heat Shield Weldment	10540401	10540402	10540403	10540404	10540405	10540406	10540407	10540408	10540409
33 End Panel, Upper Right	10531600	10531600	10531600	10531600	10531600	10531600	10531600	10531600	10531600
34 End Panel, Upper Left	10534000	10534000	10534000	10534000	10534000	10534000	10534000	10534000	10534000
35 Upper Rear Panel/Heat Shield Weldment	10540501	10540502	10540503	10540504	10540505	10540506	10540507	10540508	10540509
36 Front Panel, Upper	10531501	10531502	10531503	10531504	10531505	10531506	10531507	10531508	10531809
37 Brackets, Support, End Tile	10551000 (2)	10551000 (2)	10551000 (2)	10551000 (2)	10551000 (2)	10551000 (2)	10551000 (2)	10551000 (2)	10551000 (2)
38 Drafthood, Relief Baffle, Right	10540901	10540902	10540903	10540904	10540905	10540906	10540907	10540908	10540909
39 Drafthood, Relief Baffle, Left	10541001	10541002	10541003	10541004	10541005	10541006	10541007	10541008	10541009
40 Lower Right Panel/Heat Shield Weldment	10554601	10554602	10554603	10554604	10554605	10554606	10554607	10554608	10554609
41 Middle Front Panel	10554401	10554402	10554403	10554404	10554405	10554406	10554407	10554408	10554409
42 Sweep Sheet, Flue Collector	10533901	10533902	10533903	10533904	10533905	10533906	10533907	10533908	10533909

NOTE: Numbers in () represent quantity required for each size. Quantity is one otherwise.

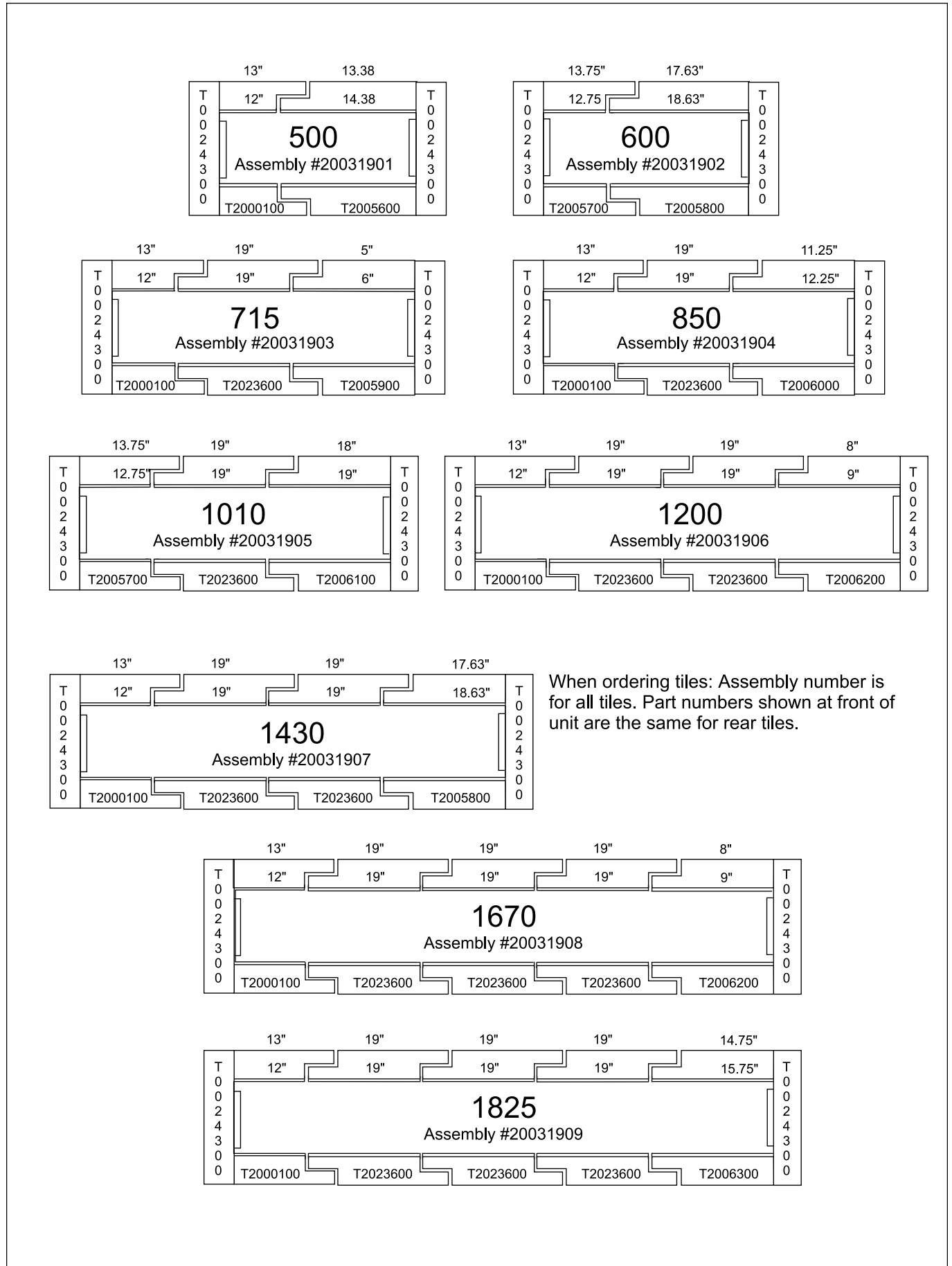

Figure 20. Tile Assemblies.

Key No	Description	Model 500	Model 600	Model 715	Model 850	Model 1010	Model 1200	Model 1430	Model 1670	Model 1825
43	Ignition Control, Electronic	E0100900	E0100900	E0100900	E0100900	E0100900	E0100900	E0100900	E0100900	E0100900
44	Transformer, 11 5V/24V	E0086100	E0086100	E0086100	E0086100	E0086100	E0086100	E0086100	E0086100	E0086100
45	Control Box Weldment	10545800	10545800	10545800	10545800	10545800	10545800	10545800	10545800	10545800
46	Control Box Cover	10547200	10547200	10547200	10547200	10547200	10547200	10547200	10547200	10547200
47	Wing Nut, #8-32	F0032100 (2)	F0032100 (2)	F0032100 (2)	F0032100 (2)	F0032100 (2)	F0032100 (2)	F0032100 (2)	F0032100 (2)	F0032100 (2)
48	Base Tile Support Assy.	10536901	10536902	10536903	10536904	10536905	10536906	10536907	10536908	10536909
49	Burner, Main	L0052300	L0052300	L0052300	L0052300	L0052300	L0052300	L0052300	L0052300	L0052300
50	Pilot Brkt/Burner Weldment (Johnson Pilot)	10529501	10529501	10529501	10529501	10529501	10529501	10529501	10529501	10529501
	(Honeywell Pilot)	10529502	10529502	10529502	10529502	10529502	10529502	10529502	10529502	10529502
51	Pilot Burner (Johnson)	W0034700	W0034700	W0034700	W0034700	W0034700	W0034700	W0034700	W0034700	W0034700
	Standing Pilot, Nat	W0035800	W0035800	W0035800	W0035800	W0035800	W0035800	W0035800	W0035800	W0035800
	Pilot Burner (Honeywell)	W0034600	W0034600	W0034600	W0034600	W0034600	W0034600	W0034600	W0034600	W0034600
	Standing Pilot, Nat	W0034400	W0034400	W0034400	W0034400	W0034400	W0034400	W0034400	W0034400	W0034400
52	Pilot Burner (Johnson)	W0034500	W0034500	W0034500	W0034500	W0034500	W0034500	W0034500	W0034500	W0034500
	Standing Pilot, Propane	W0034300	W0034300	W0034300	W0034300	W0034300	W0034300	W0034300	W0034300	W0034300
	Pilot Burner (Honeywell)	10525901	10525902	10525903	10525904	10525905	10525906	10525907	10525908	10525909
	Standing Pilot, Propane	L0050700 (22)	L0050700 (26)	L0050700 (30)	L0050700 (36)	L0050700 (42)	L0050700 (50)	L0050700 (60)	L0050700 (70)	L0050700 (76)
53	Pilot Burner (Johnson)	L0032900 (22)	L0032900 (26)	L0032900 (30)	L0032900 (36)	L0032900 (42)	L0032900 (50)	L0032900 (60)	L0032900 (70)	L0032900 (76)
	IID Pilot, Nat	10552901	10552902	10552903	10552904	10552905	10552906	10552907	10552908	10552909
	Pilot Burner (Honeywell)	10525301	10525302	10525303	10525304	10525305	10525306	10525307	10525308	10525309
	IID Pilot, Nat	10542701	10542702	10542703	10542704	10542705	10542706	10542707	10542708	10542709
54	Gas Manifold Weldment (single)	10525701	10525702	10525703	10525704	10525705	10525702 (2)	10525703 (2)	10525704 (2)	10525705
55	Orifice, Nat, Gas									
56	Orifice, Propane - 9" W.C.									
57	Manifold Cover Plat Assy.									
58	Burner, Anti Rotation Brkt (left)									
59	Burner, Anti Rotation Brkt (right)									
60	Burner Tie Down Bracket (left)									
61	Burner Tie Down Bracket (right)									
62	Valve, Manual, Gas, Natural	V0004200	V0004200	V0004200	V0004200	V0004300	V0004300	V0004300	V0004300	V0004300
63	Valve, Manual, Gas, Propane	V0004800	V0004800	V0004800	V0004800	V0004200	V0004200	V0004300	V0004300	V0004300

NOTE: Numbers in () represent quantity required for each size. Quantity is one otherwise.

Key No	Description	Model 500	Model 600	Model 715	Model 850	Model 1010	Model 1200	Model 1430	Model 1670	Model 1825	
64	Safety Gas Valve, On-Off, Two Stage (Nat)	V0046600	V0046600	V004600	V004600	V0046700	V0046700	V0046700	V0046700	V0046800	
65	Safety Gas Valve, On-Off, Two Stage (Pro)	V0046600	V0046600	V0046600	V0046600	V0046600	V0046600	V0046700	V0046700	V0046700	
66	Valve, Gas, Operating / Reg. On-Off, Two Stage (Nat)	V0051200	V0051200	V0051200	V0051200	V0051300	V0051300	V0051300	V0051400	V0051400	
67	Valve, Gas, Operating / On-Off Two Stage (Pro)	V0054800	V0054800	V0054800	V0054800	V0054800	V0054800	V0054900	V0054900	V0054900	
68	Valve, Pilot, Gas, Manual	W0002100	W0002100	W0002100	W0002100	W0002100	W0002100	W0002100	W0002100	W0002100	
69	Tube Assembly, Copper	10534701	10534702	10534703	10534704	10534705	10534706	10534707	10534708	10534709	
70	Tube Assembly, Cupro-nickel	10553701	10553702	10553703	10553704	10553705	10553706	10553707	10553708	10553709	
71	Screw, Cap, 1/2" - 13 x 4 1/2"	F0028700	F0028700	F0028700	F0028700	F0028700	F0028700	F0028700	F0028700	F0028700	
72	Screw, Cap, 1/2" - 13 x 2 1/4"	F0023100	F0023100	F0023100	F0023100	F0023100	F0023100	F0023100	F0023100	F0023100	
73	Screw, Cap, 1/2" - 13 x 1 1/2"	F0013300	F0013300	F0013300	F0013300	F0013300	F0013300	F0013300	F0013300	F0013300	
74	Washer	F0011400	F0011400	F0011400	F0011400	F0011400	F0011400	F0011400	F0011400	F0011400	
75	Plug, Sq. Hd., 1 " NPT	P0033000	P0033000	P0033000	P0033000	P0033000	P0033000	P0033000	P0033000	P0033000	
76	Plug, 1/2" NPT	P0026900	P0026900	P0026900	P0026900	P0026900	P0026900	P0026900	P0026900	P0026900	
77	Nipple, Brass, 3/4" x 2"	P0025300	P0025300	P0025300	P0025300	P0025300	P0025300	P0025300	P0025300	P0025300	
78	Valve, Press, Relief 3/4" -75 PSI	A0063600	A0063600	A0063600	A0063600	A0063600	A0063600	A0063600	A0063600	A0063600	
79	Temp/Press Gauge	A0079000	A0079000	A0079000	A0079000	A0079000	A0079000	A0079000	A0079000	A0079000	
80	Flow Switch (indoor) (outdoor)	E0013100	E0013100	E0013100	E0013100	E0013100	E0013100	E0013100	E0013100	E0013100	
81	Nipple, 2" x cl. - Galv	P0038500	P0038500	P0038500	P0038500	_____	_____	_____	_____	_____	
82	Nipple, 2 1/2" x 3" Galv	_____	_____	_____	_____	P0022000	P0022000	P0022000	P0022000	P0022000	
83	Red. Tee, 2 x 2 x 1, Galv	P0028500	P0028500	P0028500	P0028500	_____	_____	_____	_____	_____	
	Red. Tee, 2 1/2 x 2 1/2 x 1, Galv	_____	_____	_____	_____	P0055900	P0055900	P0055900	P0055900	P0055900	
84	Pump Rotating Assembly	See Current Document 2040 For Pump Requirements									
85	Pump Housing	10261501	10261501	10261501	10261501	10261501	10261501	10261501	10261501	10261501	
86	Gasket, Pump Housing	S0024600	S0024600	S0024600	S0024600	S0024600	S0024600	S0024600	S0024600	S0024600	
87	Pump Adapter	10364200	10364200	10364200	10364200	10364200	10364200	10364200	10364200	10364200	
88	Screw, Hex Hd. 1/2 - 13 x 1 3/4	F0009200	F0009200	F0009200	F0009200	F0009200	F0009200	F0009200	F0009200	F0009200	

NOTE: Numbers in () represent quantity required for each size. Quantity is one otherwise.

Key No	Description	Model 500	Model 600	Model 715	Model 850	Model 1010	Model 1200	Model 1430	Model 1670	Model 1825
89	Plug, 3/4, Sq. Hd.	P0027000	P0027000	P0027000	P0027000	P0027000	P0027000	P0027000	P0027000	P0027000
90	Pipe Extension 1/2" Female 1/2" Male									
91	Baffle, Diffuser	P0072300 10338400	P0072300 10338400	P0072300 10338400	P0072300 10338400	P0072300 10338400	P0072300 10338400	P0072300 10338400	P0072300 10338400	P0072300 10338400
92	Burner Tray, IID, 2 Stage, SGL Sect. Manifold (Nat)	10550601	10550602	10550603	10550604	10550605	10550606	10550607	10550608	10550609
93	Burner Tray, St. Pilot, 2 Stage, SGL, Sect. Manifold (Pro)	10529601	10529602	10529603	10529604	10529605	10529606	10529607	10529608	10529609
94	Burner Tray, IID, 4 Stage, Split Manifold (Nat)	10550701	10550702	10550703	10550704	10550705	10550706	10550707	10550708	10550709
95	Burner Tray, St. Pilot, 4 Stage, Split Manifold (Pro)	10550301	10550302	10550303	10550304	10550305	10550306	10330307	10330508	10330509
96	Burner Tray, IID, Mech. Mod. Split Manifold (Nat)	10550701	10550702	10550703	10550704	—	—	—	—	—
97	Burner Tray, IID, Mech. Mod., 3 & 4 Sect. Manifold (Nat)	—	—	—	—	10551201	10551202	10551203	10551204	10551205
98	Burner Tray, St. Pl. Mech. Mod. Splt. Manifold (Pro)	10550301	10550302	10550303	10550304	—	—	—	—	—
99	Burner Tray, St. Pl., Mech. Mod., 3 Sect. Manifold (Pro)	—	—	—	—	10550501	10550502	10550503	10550504	10550505
100	Combination Gas Valve, 4 Stage, (Nat)	V0059600 (2)	V0059600 (2)	V0059600 (2)	V0070400 (2)	V0070400 (2)	V0070400 (2)	—	—	—
101	Safety Gas Valve, 4 Stage (Nat)	—	—	—	—	—	—	V0046700	V0046800	V0046800
102	Operating/Reg. Gas Valve, 4 Stage (Nat)	—	—	—	—	—	—	V0051300 (2)	V0051300 (2)	V0051300 (2)
103	Combination Gas Valve, 4 Stage, (Pro)	V0070800 (2)	V0070800 (2)	V0070800 (2)	V0070900 (2)	V0070900 (2)	V0070900 (2)	V0070900 (2)	—	—
104	Safety Gas Valve, 4 Stage, (Pro)	—	—	—	—	—	—	—	V0046700	V0046700
105	Operating/Reg. Gas Valve, 4 Stage (Pro)	—	—	—	—	—	—	—	V0054900 (2)	V0054900 (2)
106	Modusnap Gas Valve, (HH & PH Only), Mech. Mod. (Nat & Pro)	V0045100 V0071100	V0045100 V0071100	V0045100 V0071100	V0045100 V0071100	— (3)	— (3)	— (3)	V0071100 N(4) & P(3)	— N(4) & P(3)
107	Operating/Reg. Gas Valve, Mech. Mod. (Nat)	V0047600	V0047600	V0047600	V0047600	V0047700	V0047700	V0047700	V0047800	V0047800
108	Operating/Reg. Gas Valve, Mech. Mod. (Pro)	V0054800	V0054800	V0054800	V0054800	V0054800	V0054800	V0054900	V0054900	V0054900

NOTE: Numbers in () represent quantity required for each size. Quantity is one otherwise.

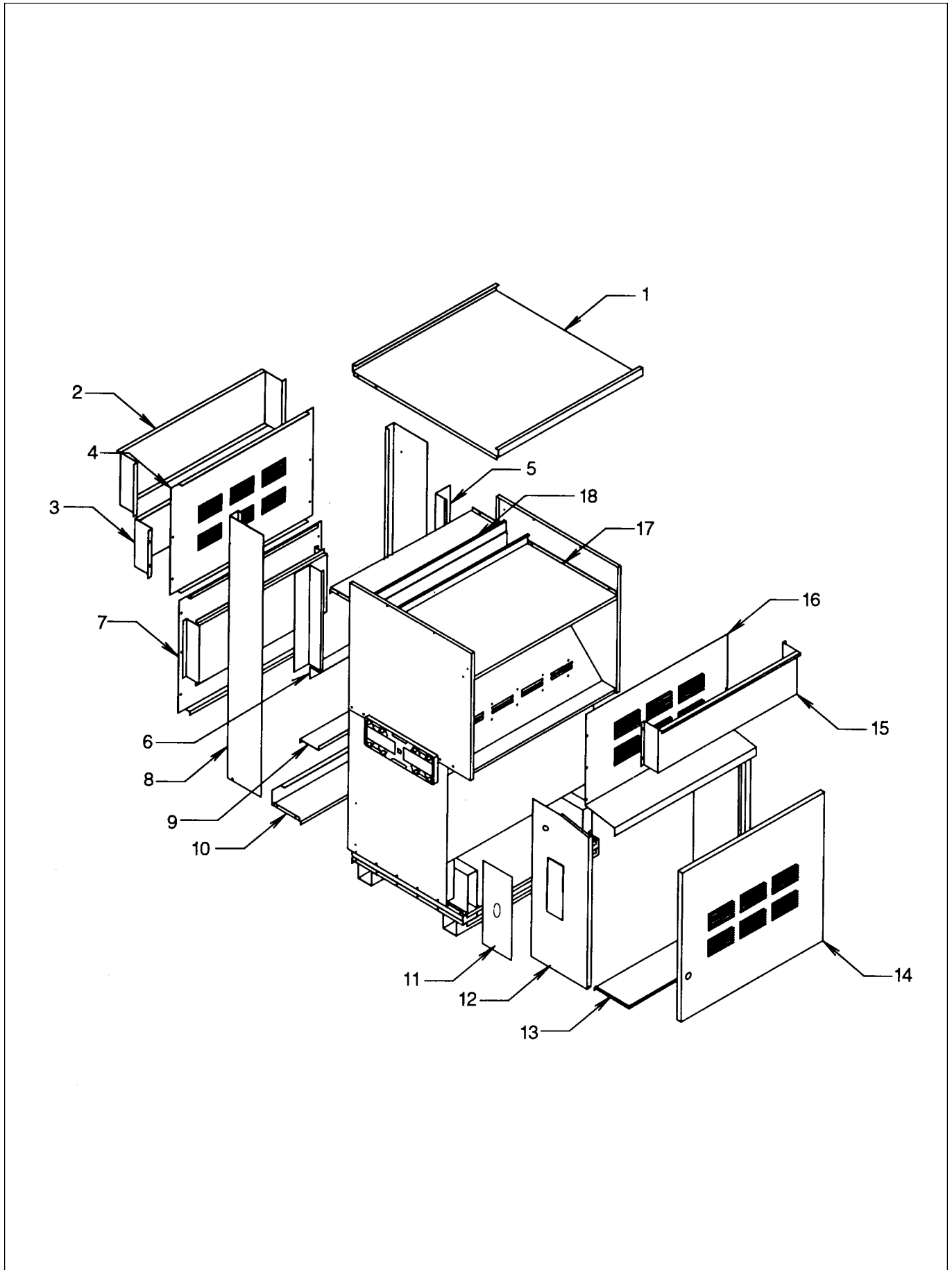

Figure 21. Outdoor Parts.

SECTION 7. Outdoor Parts Descriptions and Order Numbers

Key No	Description	Model 500	Model 600	Model 715	Model 850	Model 1010	Model 1200	Model 1430	Model 1670	Model 1825
1	Top Panel Assembly	10660701	10660702	10660703	10660704	10660705	10660706	10660707	10660708	10660709
2	Rear Windshield	10658101	10658102	10658103	10658104	10658105	10658106	10658107	10658108	10658109
3	Upper Rear Louver Shield	10657101	10657102	10657103	10657104	10657105	10657106	10657107	10657108	10657109
4	Rear Panel Upper	10658701	10658702	10658703	10658704	10658705	10658706	10658707	10658708	10658709
5	Gap Closure-Side	10660200 (2)	10660200 (2)	10660200 (2)	10660200 (2)	10660200 (2)	10660200 (2)	10660200 (2)	10660200 (2)	10660200 (2)
6	Gap Closure-Middle	10660100	10660100	10660100	10660100	10660100	10660100	10660100	10660100	10660100
7	Lower Rear Panel Assembly	10660501	10660502	10660503	10660504	10660505	10660506	10660507	10660508	10660509
8	Rear End Panel Lft. & Rt.	10657700 (2)	10657700 (2)	10657700(2) (2)	10657700 (2)	10657700 (2)	10657700 (2)	10657700 (2)	10657700 (2)	10657700 (2)
9	Lower Rear Shield Inner	10659901	10659902	10659903	10659904	10659905	10659906	10659907	10659908	10659909
10	Rear Base Extension	10658501	10658502	10658503	10658504	10658505	10658506	10658507	10658508	10658509
11	Gas Train Interface Plate	20050200	20050200	20050200	20050200	20050200	20050200	20050200	20050200	20050200
12	Front End Panel	10657500 (2)	10657500 (2)	10657500 (2)	10657500 (2)	10657500 (2)	10657500 (2)	10657500 (2)	10657500 (2)	10657500 (2)
13	Front Base Extension	10659701	10659702	10659703	10659704	10659705	10659706	10659707	10659708	10659709
14	Door	10660801	10660802	10660803	10660804	10660805 (2)	10660806 (2)	10660807 (2)	10660808 (2)	10660809 (2)
15	Front Windshield	10659101	10659102	10659103	10659104	10659105	10659106	10659107	10659108	10659109
16	Front Panel Upper	10658901	10658902	10658903	10658904	10658905	10658906	10658907	10658908	10658909
17	Flue Panel Front	10659501	10659502	10659503	10659504	10659505	10659506	10659507	10659508	10659509
18	Flue Panel Rear	10659301	10659302	10659303	10659304	10659305	10659306	10659307	10659308	10659309
19	Rain Shield-Control Box (Not shown)	10660400	10660400	10660400	10660400	10660400	10660400	10660400	10660400	10660400

NOTE: Numbers in () represent quantity required for each size. Quantity is one otherwise.

Key No	Description	Model 500	Model 600	Model 715	Model 850	Model 1010	Model 1200	Model 1430	Model 1670	Model 1825
5	Rear Panel, Flue Collector	10661701	10661702	10661703	10661704	10661705	10661706	10661707	10661708	10661709
6	Rear Panel, Flue Collector Ext.	10661801	10661802	10661803	10661804	10661805	10661806	10661807	10661808	10661809
7	Front Support, Flue Collector	10662101	10662102	10662103	10662104	10662105	10662106	10662107	10662108	10662109
8	Tile Cover, Front & Rear	10661501 (2)	10661502 (2)	10661503 (2)	10661504 (4)	10661505 (4)	10661506 (4)	10661507 (4)	10661508 (4)	10661509 (4)
10	Baffle, Heat Exchanger	10667701 (7)	10667702 (14)	10667703 (14)	10667704 (14)	10667705 (14)	10667706 (28)	10667707 (28)	10667708 (28)	10667709 (14)
41	Middle Front Panel	10662001	10662002	10662003	10662004	10662005	10662006	10662007	10662008	10662009
42	Sweep Sheet Flue Collector	10662201	10662202	10662203	10662204	10662205	10662206	10662207	10662208	10662209
48	Base Tile Support	10602301	10602302	10602303	10602304	10602305	10602306	10602307	10602308	10602309
69	Tube Assembly, Copper	10665901	10665902	10665903	10665904	10665905	10665906	10665907	10665908	10665909
70	Tube Assembly, Cupro-Nickel	10670401	10670402	10670403	10670404	10670405	10670406	10670407	10670408	10670409

See Parts Illustration On Page 21

NOTE: Numbers in () represent quantity required for each size. Quantity is one otherwise.

SECTION 8. Optional Parts Descriptions and Order Numbers

Pump Rotating Sections and Repair Parts

Standard PH Model Pumps (Armstrong 1050)		
PH Model	Part Number	Description
500-850	A2000700	1/3 hP with 3-1/2" Impeller
1010-1200	A2000800	1/2 hP with 4-1/4" Impeller
1430-1670	A2000900	3/4 hP with 5-1/4" Impeller

Optional PH Model Pumps (B&G 1522)		
PH Model	Part Number	Description
500-715	A0048600	1/4 hP with 3-1/2" Impeller
850-1010	A0047100	1/3 hP with 4" Impeller
1200-1825	A0047300	3/4 hP with 5-1/4" Impeller

Standard Pump Replacement Parts (for standard Armstrong 1050 pumps only)	
Description	Part Number
Coupler Assembly	A2010500
Shaft & Bearing Module	A2010100
Mechanical Seal Assembly	A2010000
Impeller for A2000700 (3-1/2")	A2010200
Impeller for A2000800 (4-1/4")	A2010301
Impeller for A2000900 (5-1/4")	A2010302
Motor Assembly	A2010303

Electrical Options

Automatic Reset Temp. Limit Switch	E0014400
Manual Reset High Gas Pressure Switch	E0023300
Manual Reset Low Gas Pressure Switch	E0023500
Outdoor Reset, On/Off 1:1 Reset Ratio	E0067600
Outdoor Reset, Two Stage, 1:1 Reset Ratio	E0084200
Outdoor Reset, Two Stage, 1:1.5 Reset Ratio	E0081900
Low-water Cut-off, Electronic, Manual Reset	E2075100

Gas valve types and sizes vary with different boiler models, with different fuels and with different firing options. For service and replacement, copy exact number from nameplate giving manufacturer's name and pipe size.

Energy Management Monitor (EM²)

STANDARD COMPONENTS	
Description	Part No.
On/Off Auto Switch	E0109200
Time Delay Relay, 24 VAC	E2077700
OPTIONAL EQUIPMENT	
Description	Part No.
Remote Aquastat, 110-240F	E0014400
Immersion Well	E0025900
Note: The Remote Aquastat and the Immersion Well, when required, should be ordered separately.	

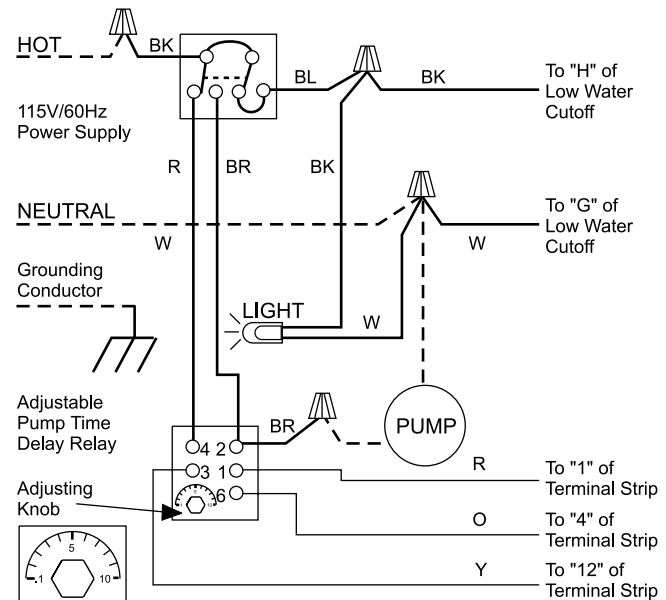

WIRING CODE

Factory Wiring Field Wiring
 24 Volt 110 Volt
 110 Volt

BK — Black R — Red
 BL — Blue Y — Yellow
 BR — Brown W — White
 O — Orange

