

FOR YOUR SAFETY - This product must be installed and serviced by a professional service technician, qualified in pool heater installation. Improper installation and/or operation could create carbon monoxide gas in flue gases which could cause serious injury, property damage, or death. Improper installation and/or operation will void the warranty.

Installation and Operation Manual

Lite2 Pool and Spa Heater

Model LJ Natural Gas or LP Gas

**NOTE: LP Gas For
Outdoor Use Only**

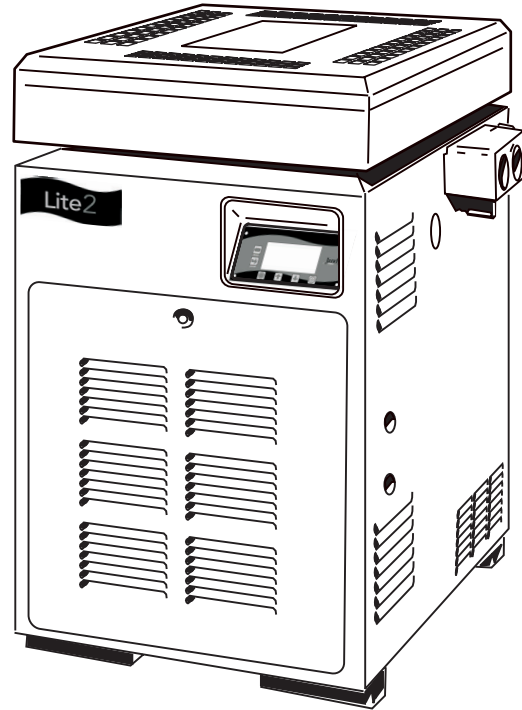

⚠ WARNING: If these instructions are not followed exactly, a fire or explosion may result, causing property damage, personal injury, or death.

Do not store or use gasoline or other flammable vapors and liquids in the vicinity of this or any other appliance.

WHAT TO DO IF YOU SMELL GAS

- **Do not try to light any appliance.**
- **Do not touch any electrical switch; do not use any phone in your building.**
- **Immediately call your gas supplier from a nearby phone. Follow the gas supplier's instructions.**
- **If you cannot reach your gas supplier, call the fire department.**

Installation and service must be performed by a qualified installer, service agency, or the gas supplier.

To the Installer: After installation, these instructions must be given to the homeowner or left on or near the heater.

To the User: This booklet contains important information that will help you in operating and maintaining this heater. Please retain it for future reference.

TABLE OF CONTENTS

SECTION 1. General Information

1.1	Introduction	1
1.2	Consumer Information and Safety	1
1.2.1	Spa/Hot Tub Safety Rules	1
1.2.2	Swimming Pool Energy Safety Tips	2
1.3	Warranty	2
1.4	Codes and Standards	2
1.5	Technical Assistance	2
1.6	Materials Installer Must Provide	2
1.6.1	Materials for All Applications	2
1.6.2	Materials for Special Applications	3
1.7	Specifications	3
1.7.1	General Specifications	3
1.7.2	Dimensions	3

SECTION 2. Installation Instructions

2.1	Introduction	3
2.2	Field Assembly	4
2.3	Location Requirements	5
2.3.1	Introduction	5
2.3.2	Clearances	5
2.3.3	Flooring	5
2.3.4	Outdoor Installation	6
2.3.5	Indoor and Outdoor Shelter Installation	6

SECTION 3. Venting

3.1	Combustion Air Supply	7
3.2	Vent Pipe Sizing and General Installation	8
3.2.1	Outdoor Installations	8
3.2.2	Indoor and Outdoor shelter Installations	8

SECTION 4. Gas Connections

4.1	Gas Supply and Piping	9
4.2	Special Precautions for Propane Gas	11

SECTION 5. Water Connections

5.1	Water Piping	11
5.2	Check Valve Installation	11
5.3	Automatic Flow Control Valve	11
5.4	Reversible Water Connections	11
5.5	Connections at Heater	13
5.6	Pressure Relief Valve	14
5.7	Auxiliary Components, Chlorinators, Ozone Generators, and Sanitizing Chemicals	14

SECTION 6. Electrical

6.1	General Information	15
6.2	Main Power	15
	Wiring Diagram	16
6.3	Bonding	17
6.4	Pump Power Connection	17

SECTION 7. Operating Instructions

7.1	Start-Up	18
7.2	Setting the TC2000 Controller Functions and Limits	19

SECTION 7. Operating Instructions

(Continued)

7.2.1	Setting the Real Time Clock	19
7.2.2	Setting the Temperature Scale	20
7.2.3	Setting Pool and Spa Temperatures	20
7.2.4	Setting the Freeze Temperature	21
7.2.5	Setting the Pump Time Clock	21
7.3	Lighting and Shutdown Procedures	22
7.4	Heater/Controller Operation	22
7.4.1	Normal Operation	22
7.4.2	Pump Operation	24
7.4.3	Locking/Unlocking the Keypad	24
7.5	Remote Control Operation	24
7.6	Adjusting the Pressure Switch	25
7.7	Temperature Rise	26
7.8	Adjusting the Manual Bypass Valve	27

SECTION 8. Maintenance

8.1	Water Chemistry	27
8.2	Seasonal Care	28
8.2.1	Spring and Fall Operation	28
8.2.2	Winterizing	28
8.2.3	Spring Start-up	29
8.3	Inspection and Service	29
8.3.1	Owner Inspection	29
8.3.2	Professional Inspection	29

SECTION 9. Trouble Shooting

9.1	General Heater Trouble Shooting Guide	30
9.2	TC2000 Error Codes	31
9.2.1	Explanation of Error Codes	31
9.2.2	Resetting TC2000 Error Codes	32

SECTION 10. Professional Maintenance and Service

10.1	General Information	34
10.2	Natural Draft Combustion System	34
10.3	Heater Components and Their Operation	34
10.4	Electrical Troubleshooting	37
10.4.1	Electrical Power Supply	37
10.4.2	Controller	37
10.4.3	Control Circuit Troubleshooting	37
10.4.3.1	Transformer	37
10.4.3.2	Fuse	37
10.4.3.3	Fireman Switch and External Interlocks	38
10.4.3.4	Fusible Link	38
10.4.3.5	Limit Switches	38
10.4.3.6	Water Pressure Switch	38
10.4.3.7	Gas Valve Voltage	38
10.4.3.8	Igniter/Ignition Control	39

SECTION 11. Replacement Parts

11.1	Ordering Information	39
11.2	Parts List	39
11.3	General Exploded View	41
11.4	Detailed Exploded View	42
	Warranty	Back Cover

SECTION 1.

General Information

1.1 Introduction

This manual provides installation and operation instructions for the Lite2 Model LJ pool and spa heaters. Read these installation and operation instructions completely before proceeding with the installation. Consult the Jandy factory, or local factory representative, with any questions regarding this equipment.

Certain sections of this manual are specific to either United States or Canadian installations, and are labeled as such.

The Lite2 LJ heater gets electrical power from an external 115VAC or 230VAC source and provides a dual electronic thermostat control system for pool/spa combinations or preheat convenience.

The Lite2 LJ heater is specifically designed for heating fresh, nonpotable water swimming pools and spas. Do not use it as a general service water heater. There is a specially designed model of Lite2 for heating salt water pools. Consult your dealer for the appropriate Jandy products for these applications.

1.2 Consumer Information and Safety

The Lite2 Pool/Spa heater is designed and manufactured to provide many years of safe and reliable service when installed, operated and maintained according to the information in this manual and the installation codes referred to in later sections. Throughout the manual, safety warnings and cautions are identified by the "▲" symbol. Be sure to read and comply with all of the warnings and cautions.

1.2.1 Spa/Hot Tub Safety Rules

▲ WARNING

The following "Safety Rules for Hot Tubs," recommended by the U.S. Consumer Product Safety Commission, should be observed when using the spa.

▲ WARNING

The U.S. Consumer Product Safety Commission warns that elevated water temperature can be hazardous. Consult heater operation and installation instructions for water temperature guidelines before setting temperature.

▲ AVERTISSEMENT

La U.S. Consumer Product Safety Commission indique que des températures de l'eau élevées peuvent être dangereuses. Voir la notice d'installation et de fonctionnement pour le réglage de la température.

1. Spa or hot tub water temperature should never exceed 104°F (40°C). One hundred degrees Fahrenheit (100°F [38°C]) is considered safe for a healthy adult. Special caution is recommended for young children.
2. The drinking of alcoholic beverages before or during spa or hot tub use can cause drowsiness which could lead to unconsciousness, and subsequently result in drowning.
3. **Pregnant women take note!** Soaking in water above 102°F (38.5°C) can cause fetal damage during the first three months of pregnancy (which could result in the birth of a brain-damaged or deformed child). If pregnant women are going to use a spa or hot tub, they should make sure the water temperature is below 100°F (38°C) maximum.
4. The water temperature should always be checked with an accurate thermometer before entering a spa or hot tub. Temperature controls may vary by as much as 1F° (1C°).
5. Persons with a medical history of heart disease, diabetes, circulatory or blood pressure problems should consult their physician before using a hot tub or spa.
6. Persons taking any medication which induces drowsiness (e.g., tranquilizers, antihistamines, or anticoagulants) should not use spas or hot tubs.
7. Prolonged immersion in hot water can induce hyperthermia.

Hyperthermia occurs when the internal body temperature reaches a level several degrees above the normal body temperature of 98.6°F (37°C). Symptoms include dizziness, fainting, drowsiness, lethargy, and an increase in the internal body temperature. The effects of hyperthermia include:

- Lack of awareness of impending hazard
- Failure to perceive heat
- Failure to recognize need to leave spa
- Physical inability to leave spa
- Fetal damage in pregnant women
- Unconsciousness resulting in a danger of drowning

1.2.2 Swimming Pool Energy Saving Tips

Water Pik Technologies offers the following recommendations to help conserve fuel and minimize the cost of operating your pool heater without sacrificing comfort.

1. The American Red Cross recommends a maximum water temperature of 78°F (25°C). Use an accurate pool thermometer. A difference of 4F° (2C°), between 78°F and 82°F (26°C and 28°C), will use as much as 40% more gas.
2. Carefully monitor the water temperature of your pool in the summertime. You can reduce heater usage due to warmer air temperatures.
3. Find the proper setting on the pool heater temperature control and use the Keypad Lock function to discourage further adjustments.
4. Set the pump time clock to start the pump no earlier than 6:00 AM during the pool heating season. This is the time when nightly heat loss balances.
5. If the pool is only going to be used on weekends, reduce the heater temperature control setting by 8 or 10 degrees during the week. Reset it to the 78°F (25°C) level a day or so before you plan to use the pool.
6. During the winter or when on vacation for longer than a week, shut down the heater by following the shutdown instructions found on the inside of the heater.
7. Where possible, shelter the pool from prevailing winds with well-trimmed hedges or other landscaping, cabanas, or fencing.
8. Always use a pool cover when practical. Besides providing a valuable safety feature, a pool cover will reduce heat loss, conserve chemicals, and reduce the load on filter systems.

1.3 Warranty

The Lite2 heater is sold with a limited factory warranty. Details are specified on the back cover of this manual.

Make all warranty claims to an authorized Jandy representative or directly to the factory. Claims must include the heater serial number and model (this information can be found on the rating plate), installation date, and name of the installer. Shipping costs are not included in the warranty coverage.

The warranty does not cover damage caused by improper assembly, installation, operation or field modification. Also, damage to the heat exchanger by corrosive water is NOT covered by the warranty. See Section 8.1 for maintaining proper pool water chemistry.

NOTE: Keep this manual in a safe place for future reference when inspecting or servicing the heater.

1.4 Codes and Standards

The Lite2 pool and spa heater is design certified by CSA (Canadian Standards Association) as complying with the latest edition of the "American National Standard/CSA Standard for Gas Fired Pool Heaters", ANSI Z21.56•CAN1-4.7 .

All Jandy heaters must be installed in accordance with the local building and installation codes as per the utility or authorities having jurisdiction. All local codes take precedence over national codes.

In the absence of local codes, refer to the latest edition of the following national codes for installation:

1. In the United States, "The National Fuel and Gas Code", ANSI Z223.1. Specifically, refer to Part 7, "Venting of Equipment".
2. In Canada, "The Installation Codes for Gas Burning Appliances and Equipment", CAN/CGA B149.

Any changes to the heater, gas controls, gas orifices, wiring, draft hood, vent cap, or improper installation may void the warranty. If change is required to any of the above, consult the factory.

1.5 Technical Assistance

Consult Water Pik Technologies or your local Jandy distributor with any questions or problems involving the specifications, installation, and operation of your Jandy equipment. An experienced technical support staff is ready to assist you in assuring the proper performance and application of Jandy products. For technical support call the Jandy Products Technical Service Department at (707) 776-8200 extension 260.

1.6 Materials Installer Must Provide

1.6.1 Materials for All Applications

The following items are needed and are to be supplied by the installer for all Lite2 heater installations:

1. The correct size gas pipe to supply gas from the meter to the heater (see Section 4.1 for correct gas pipe size).
2. A manually operated gas valve to be installed in the gas line outside of the heater jacket.
3. A suitable gas union joint to connect the heater to the gas line outside of the heater.

4. Plumbing items needed to provide a sediment trap (drip leg) in the gas line between the manual gas valve and the union to the heater (see Section 4.1).
5. A 115V AC or 230V AC power supply. A junction box is not needed at the heater, connections are made inside of the heater jacket.

1.6.2 Materials for Special Applications

In addition to the items listed above, the following items are needed for special applications.

1. A factory authorized draft hood and any vent pipe needed for indoor installations in the USA and outdoor shelter installations in Canada (see Section 3.2.2). Draft hoods are available from any Jandy distributor.
2. Primer and cement suitable for cementing CPVC pipe to PVC pipe and an appropriate coupling for connecting the factory supplied CPVC pipe nipples to PVC pool plumbing.
3. A non combustible platform for installation on combustible surfaces (see Section 2.3.3). Non combustible bases are available from your Jandy distributor.
4. A factory approved vent cap for all outdoor installations in Canada and locations in the USA where wind conditions may cause downdrafting. Vent caps are available from your Jandy distributor.
5. Electrical relay (Jandy part number R0658100) if pump is to be run by the heater's internal time clock.

1.7 Specifications

1.7.1 General Specifications

1. Installation Location.
 Certified for use:
 In the USA:
 Natural Gas: Indoor and Outdoor
 Propane Gas: Outdoor Only
 In Canada:
 Natural Gas: Outdoor and Outdoor Shelter
 Propane Gas: Outdoor Only
2. Minimum Clearance From Combustible Material:
 See Table 1 in Section 2.3.2
3. *Gas Pipe/Heater Gas Valve Connection.
 Natural and LP: 3/4" NPT
 *For diameter of gas line from meter to heater see Table 3 in Section 4.1.

4. Supply Gas Type.
 Certified for use with:
 Natural Gas and Liquefied Petroleum Gas (LP Gas or Propane Gas).
5. Inlet Gas Supply Pressure.

	Minimum	Maximum
Natural Gas:	5.5 "WC	10.0 "WC
LP Gas:	10.0 "WC	14.0 "WC
6. Water Pipe/Heater Connection.

	Threaded	Unthreaded
Iron Pipe	2" NPT	1 1/2"
Copper Pipe		1 1/2" or 2"
Plastic		2"
7. Flow Rate:
 Maximum: 125 gpm (475 lpm)
 Minimum: 30 gpm (110 lpm)
8. Maximum Working Water Pressure: 75 psi
9. Exhaust Vent Connection Size: See Figure 1 in Section 2.2.
10. Electrical Supply: Either 115 volts AC or 230 volts AC.
11. Modification of Heater for High Altitude:
 None. Lite2 LJ heaters are factory built to altitude ranges as specified when ordered. For the definition of the altitude ranges, see Table 3 in Section 4.1.

1.7.2 Dimensions

See Figure 1 for a diagram showing the heater's exterior dimensions and dimensions to critical connections on the heater.

SECTION 2. Installation Instructions

2.1 Introduction

⚠ WARNING

Improper installation or maintenance can cause nausea or asphyxiation from carbon monoxide in flue gases which could result in severe injury, or death.

Install the Lite2 heaters, vent caps and draft hoods in accordance with the procedures in this manual, local codes and ordinances, and in accordance with the latest edition of the appropriate national code (see Section 1.4 "Codes and Standards").

All gas-fired products require correct installation to assure safe operation. The requirements for pool heaters include the following:

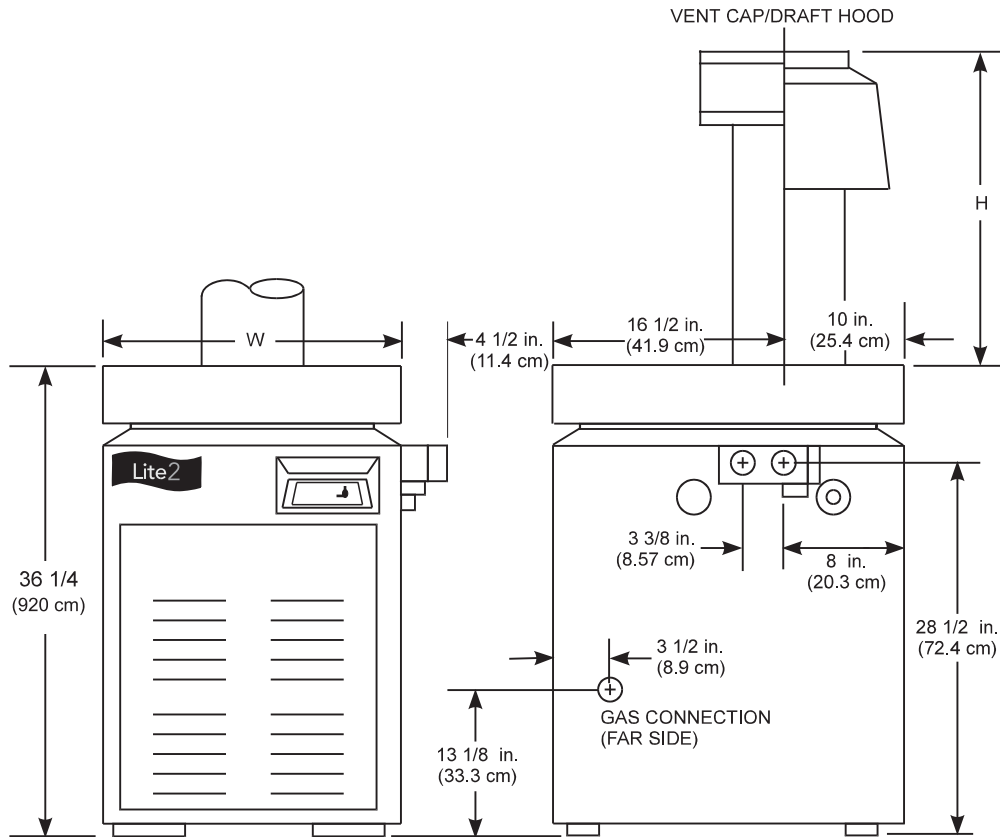

Model	Heater Width Dim "W"		Venting Dimensions				Firing Rate / Hr.* (1,000's)			
			Vent Diameter		U.S. Outdoor Dim "H"				U.S. Indoor or CAN Outdoor Shelter Dim "H"	
	in	(cm)	in	(cm)	in	(cm)	in	(cm)	BTU	(kcal)
LJ125	15	(38)	5	(13)	17 3/8	(44)	16 1/4	(41)	125	(32)
LJ175	18	(46)	6	(15)	18	(46)	24 1/8	(61)	175	(44)
LJ250	22 1/2	(57)	7	(18)	18 1/4	(47)	25 1/4	(64)	250	(63)
LJ325	26 3/4	(68)	8	(20)	18 7/8	(48)	26 1/2	(67)	325	(82)
LJ400	31 3/4	(81)	9	(23)	21 1/2	(55)	27 1/2	(70)	400	(101)

* Ratings shown are for both natural and propane gas.

Figure 1. General Configuration.

1. Field assembly (if required)
2. Appropriate site location (clearances) and flooring
3. Sufficient combustion and ventilation air
4. Properly sized gas meter and piping
5. Proper electrical wiring (if required)
6. Adequate water flow

This manual provides the information needed to meet these requirements. Review all application and installation procedures completely before continuing the installation.

2.2. Field Assembly



The Lite2 heater is shipped from the factory with the top assembly in the low-profile configuration for outdoor installation in the U.S. In Canada, an outdoor installation requires the addition of a factory approved vent cap. The Lite2 heater is design certified for indoor installation when equipped with a draft hood, which must be installed without modification.

The Lite2 heater is also certified for installation in an outdoor shelter in Canada when equipped with a draft hood. An outdoor shelter is an enclosure not normally occupied which does not communicate directly with occupied areas.

Check the rating plate on the heater or the Parts List (Section 10) of this manual for the correct Jandy draft hood or vent cap part number. See instructions supplied with the draft hood or vent cap for installation and attachment. When the draft hood is used, locate the heater so as to be in the same atmospheric pressure zone as the combustion air inlet to the heater.

2.3 Location Requirements

2.3.1 Introduction

 WARNING
Improper installation or maintenance can cause nausea or asphyxiation from carbon monoxide in flue gases which could result in severe injury, or death.
 Caution
When pool equipment is located below the pool surface, a leak from any component can cause large scale water loss or flooding. Water Pik Technologies cannot be responsible for such water loss or flooding or resulting damage.

Avoid placing the heater in locations where it can cause damage by water or condensate leakage. If this is not possible, provide a suitable drain pan to catch and divert any leakage. The pan must not restrict the air flow around the heater.

All criteria given in the following sections reflect minimum clearances as stated in the national standards. However, each installation must also be evaluated, taking into account the prevailing local conditions such as wind speed and direction, proximity and height of walls that may block ventilation or cause down drafts, and proximity to public access areas.

2.3.2 Clearances

The heater must be placed to provide clearances on all sides for maintenance and inspection. There must also be minimum distances maintained from combustible surfaces (see Table 1).

At least 20" (500mm) access must be available in front of the heater for burner removal.

If the heater is to be installed in a garage, or similar structure, all burners and burner ignition devices must have a minimum 18" (457mm) clearance above the floor.

This heater must be installed at least 5 feet (1.3 meters) from the inside wall of the pool or spa unless the heater is separated from the pool or spa by a 5 foot high solid fence, wall or other permanent barrier.

Ce chauffe-piscine doit être installé à au moins 5 pieds (1.52m) de la paroi interne de la piscine à moins d'être isolé de la piscine par une clôture, un mur ou autre barrière permanente.

2.3.3 Flooring

The heater must be installed on a floor of non-combustible construction or on fire-resistant slabs or arches. Noncombustible flooring is defined as flooring material and surface finish not capable of being ignited and burning and with no combustible materials against the underside. Acceptable materials are those consisting entirely of a combination of steel, iron, brick, tile, concrete, slate, glass or plaster. **Do not** install the heater directly on a combustible wood or carpet floor without placing a noncombustible platform between the floor and the heater.

The heater can be installed on a combustible floor if a noncombustible base assembly, available from Jandy, is used. See the heater rating plate or the Parts List (Section 10) of this manual for the appropriate base part number. **Heaters must never be installed directly on carpeting.**

As an alternative to the Jandy noncombustible base plate, in the United States, the National Fuel Gas Code allows a heater to be placed on a combustible surface when there is a platform under the heater made of hollow masonry no less than 4 inches (102 millimeters [mm]) thick, covered with sheet metal at least 24 gauge thick and extending beyond the full width and depth of the heater by at least 6 inches (76.2 mm) in all directions. The masonry must be laid with ends unsealed, and joints matched to provide free circulation of air from side to side through the masonry (see Figure 2). If the heater is installed in a carpeted alcove, the entire floor of the alcove must be covered by a noncombustible panel.

Table 1. Minimum Heater Clearances From Combustible Surfaces

SIDE OF HEATER	INDOOR (OUTDOOR SHELTER INSTALLATION)		OUTDOOR INSTALLATION	
	INCHES	CENTIMETERS	INCHES	CENTIMETERS
BLANK	6	15	6	15
REAR	6	15	6	15
PIPING	12	30	12	30
TOP	44	110	OPEN UNROOFED AREA	
FRONT	20	50	20	50

Note: Clearances listed in Table 1 are manufacturer's tested values. These are given as minimum values. Where local and national codes apply, and values are different than those listed in Table 1, use the greater value to ensure safe operation.

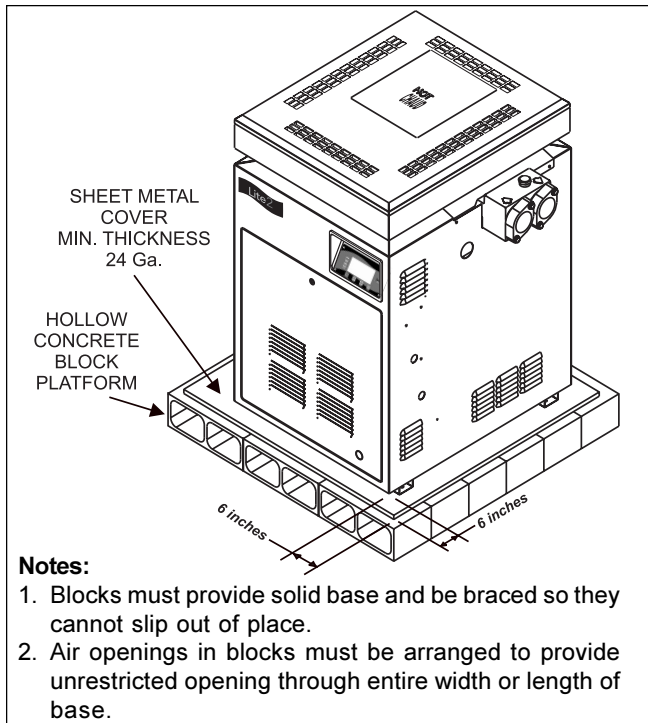

Figure 2. Non-Combustible Platform.

2.3.4. Outdoor Installation

Lite2 heaters can be installed in the low-profile, configuration as received from the factory, or with an optional factory approved vent cap for high wind applications.

Locate the heater in an **open, unroofed area**. Do not install the heater under a deck.

Do not locate the heater below or adjacent to any doors, glass openings, louvers, grills, etc., which connect in any way with an inhabited area of a building, even though the access might be through another structure (e.g., a garage or utility room). In the United States there must be a minimum of four (4) feet (1.22 m) horizontally **or** four (4) feet (1.22 m) vertically between the heater exhaust point and any door, glass opening, or gravity inlet to a building. In Canada, the heater must be installed so that the exhaust point of the heater is at least ten (10) feet (3.0 m) from any building opening (see Figure 3).

⚠ WARNING United States

Do not install the heater with the top of the vent assembly within 4 feet (1.22 m) horizontally and 4 feet (1.22 m) vertically of any opening into a building.

Canada

Do not install the heater with the top of the vent assembly within 10 feet (3.05 m) of any opening into a building.

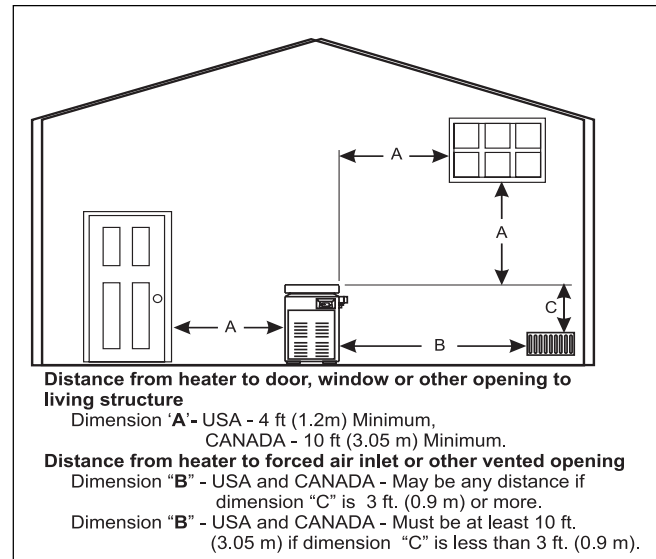

Figure 3. Outdoor Heater Installation.

The top surface of the heater must be at least three(3) feet above any forced air inlet, or intake ducts located within ten(10) feet horizontally.

If the heater is installed under an overhang, there must be a minimum clearance of 5 feet (1.5 m) above the top of the heater and the structure should not overhang the heater more than 12 inches (0.30 m). The area under the overhang must be open on three sides. This prevents combustion gases from being diverted into living areas through doors, windows, or gravity inlets.

Ne pas installer ce chauffe-piscine sous une saillie mesurant moins de 3 pi de hauteur. La partie sous la saillie doit être ouverte sur 3 côtés.

If the heater is installed close to a structure, protect it from rain water runoff with rain gutters on the roof or other measures. Do not locate the heater near irrigation sprinkler systems that could spray water on it. Water from sprinklers may cause damage to controls and electronic components.

Avoid locations where wind deflection off nearby structures might cause downdraft conditions. Where downdraft conditions exist, locate the heater at least 3 feet (0.91 m) from vertical surfaces (e.g., nearby buildings and walls). The addition of a vent cap may be necessary.

2.3.5. Indoor and Outdoor Shelter Installations

An outdoor shelter (Canada only) is an unoccupied enclosure which does not communicate directly with occupied areas. All indoor installations and outdoor shelter installations require the addition of a factory approved heater draft hood. The draft hood must be installed without modification and in accordance with the instructions provided by the manufacturer.

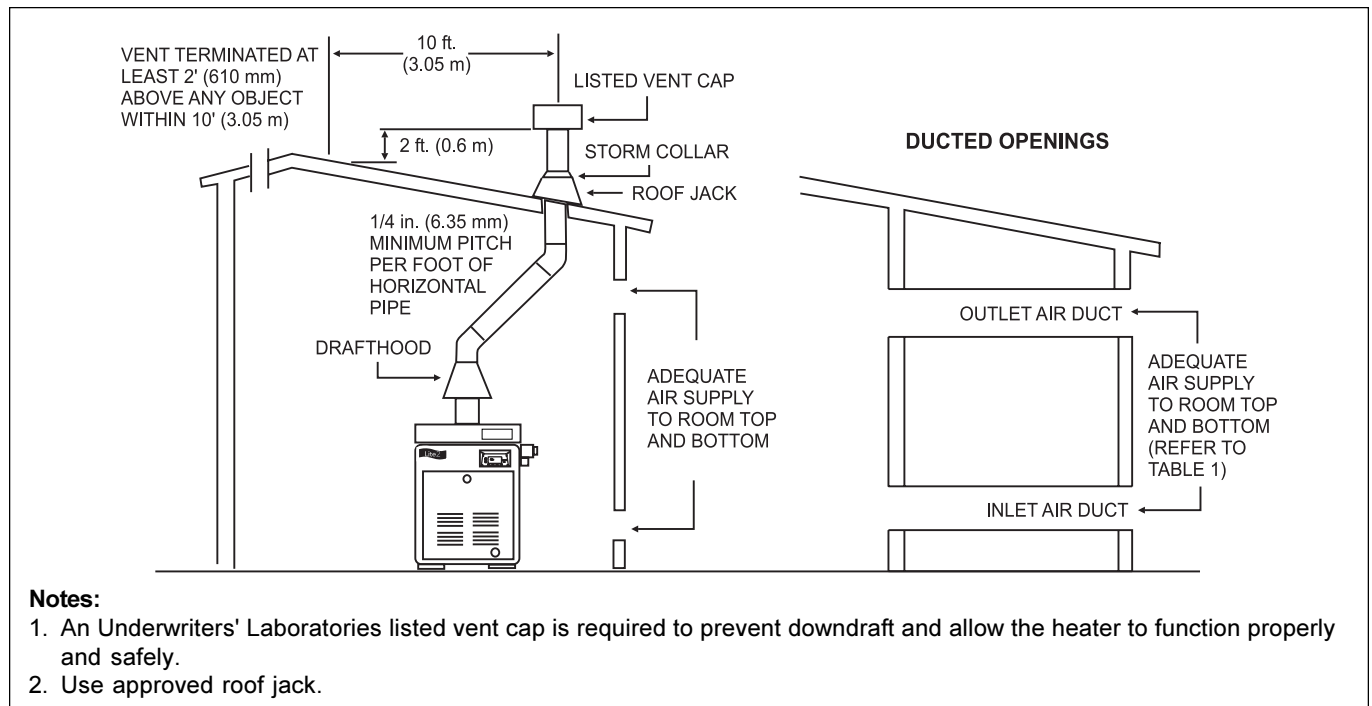

Figure 4. Indoor Installation Venting (USA), or Outdoor Shelter (Canada).

Table 2. Air Openings to Outside.

Model	Required Net Free Open Area* for Combustion Air Openings		Duct from outside	
	Direct from outside in ²	(cm ²)	in ²	(cm ²)
125	32	(206)	64	(413)
175	44	(284)	88	(568)
250	63	(406)	126	(813)
325	82	(429)	164	(1058)
400	100	(645)	200	(1290)

*Area indicated is for one of two openings; one at floor level and one at the ceiling, so the total net free area would be double the figures indicated. For special conditions, refer to NFPA54 ANSI Z223.1. In Canada refer to the National Standard CAN1-B149.1 or .2 which differs from this table.

Note: If using screens and/or metal louvers, compensate by adding 50% additional area to each opening

If using wood louvers each opening must be at least four times the area indicated in the table above.

Une remise extérieure (au Canada seulement) est un endroit inoccupé qui ne communique pas directement avec les endroits occupés. Toutes les installations intérieures et remises extérieures exigent l'addition d'une coupe-tirage intérieur approuvée par le manufacturier. La coupe-tirage intérieur doit être installée sans aucune modification et selon les exigences fournies par le manufacturier.

These codes, standards and Water Pik Technologies require that the heater be properly vented as outlined in this manual. Proper ventilation of exhaust and combustion air are essential for the safe and efficient operation of the heater (See Section 3).

SECTION 3. Venting

3.1. Combustion Air Supply

The heater location must provide sufficient air supply for proper combustion and ventilation of the surrounding area as outlined in the latest edition of ANSI standard Z223.1 or in Canada, CAN/CGA-B149.1 or .2, and any local codes that may be applicable.

In general, these requirements specify that the room in which a heater is installed should be provided with two permanent air supply openings; one within 12 inches (305mm) of the ceiling, the other within 12 inches (305mm) of the floor. All indoor installations must have openings to outside air for combustion, ventilation, and dilution of flue gases from inside the building (see Figure 4 and Table 2). Water Pik Technologies does not recommend indoor installations that do not provide combustion air from outside the building.

All outdoor shelter installations (Canada only) must have uninterrupted openings to outside air for combustion and ventilation. The installation must be in accordance with the latest edition of CAN/CGA B149. Water Pik Technologies does not recommend outdoor shelter installations that depend on internal air for combustion. Combustion air should be ducted to the heater from outside the structure.

Outside Air Supply: When combustion air is supplied directly through an outside wall, each opening should have a minimum free area of one square inch per 4,000 BTU/h (1.2kW) input of the total input rating of all appliances in the enclosed area. If air is provided through horizontal ducts, each opening and duct must provide one square inch of flow area for each 2000 BTU/h (0.6 kW). These requirements are summarized in Table 2. Note that the areas specified are net free areas and should be increased when the openings are covered by screens, louvers, grills or other protective covers (see Figure 4 and Table 2 notes).

Note: In Canada, follow Canadian Standard, CAN/CGA-B149.1, .2 or local codes.

Exhaust Fans or Vents: Any equipment which exhausts air from the room where the heater is installed can deplete the combustion air supply or reverse the natural draft action of the venting system. This could cause flue products to accumulate in the room. Additional air must be supplied to compensate for such exhaust.

The information in Table 2 is not applicable in installations where exhaust fans or blowers of any type are used. Such installations must be designed by qualified engineers.

The heater must be completely isolated and protected from any source of corrosive chemical fumes such as those emitted by trichlorethylene, perchloroethylene, chlorine, etc.

WARNING

Do not store any chemicals, cleaners, or other corrosive material near combustion air openings or in the room. Avoid locating dryer vents in the vicinity of combustion air openings. Failure to prevent corrosive materials from mixing with combustion air can result in reduced heater life and unsafe heater operation.

AVERTISSEMENT

Ne pas entreposer ni utiliser d'essence ni d'autres vapeurs ou liquides inflammables à proximité de cet appareil ou de tout autre appareil.

3.2 Vent Pipe Sizing and General Installation

3.2.1. Outdoor Installations

For outdoor installations, exhaust venting considerations will determine the placement of the heater (See Section 2.3.4). If the heater cannot be placed so as to meet the requirements stated in Section 2.3.4, a vent pipe and cap may be added to the heater to move the exhaust vent opening to a position that complies with the requirements. When the heater is installed in areas of high wind or when unavoidably installed near a vertical obstruction where downdrafting may occur, it may be desirable to add a vent cap directly to the top of the heater. In all cases, vent pipes and caps must be of the same diameter as the exhaust outlet of the heater. Approved vent caps may be obtained through your Jandy distributor.

3.2.2. Indoor and Outdoor Shelter Installations

WARNING

Vent pipe diameter must be as required by the National Fuel Gas Code Z223.1 or the Canadian Installation Codes for Gas Appliances CAN 1-B149.1 & 2. Undersize pipe can result in inadequate venting and oversize pipe can result in vent condensation. In either case the result can be release of combustion products to the indoors. This can cause serious injury or death by carbon monoxide poisoning or asphyxiation.

All indoor installations and outdoor shelter installations require the addition of a factory approved draft hood. The draft hood must be installed without modification.

All vent installations must be made in accordance with all local, state or provincial codes and with:

1. Chapter 7, "Venting of Equipment" of the national Fuel Gas Code, ANSI 223.1 latest edition, or the applicable provisions of the local building codes.
2. In Canada, CAN/CGA B149.1 or .2.

Avoid long horizontal runs of the vent pipe, and 90° elbows, reductions and restrictions. Horizontal runs should have at least a 1/4 inch rise per foot (20mm per meter) in the direction of flow.

Avoid terminating heater vents near air conditioning or air supply fans. The fans can pick up exhaust flue products from the heater and return them inside the building, creating a possible health hazard.

Do not locate the vent terminal where flue products could strike against building materials and cause degradation.

Vent opening should be well away from trees or other obstructions that would prevent free air flow to and from vent terminal. Do not terminate the vent under decks, stairways, or car ports.

Be sure to support all venting so that connections will not separate and so that the weight of the vent pipe does not rest on the heater draft hood. All connections should be made with rustproof sheet metal screws. Do not weld or fasten the vent pipe to the heater draft hood. The draft hood and heater top must be easily removable for normal heater service and inspection.

The draft hood outlet is to be connected to an unobstructed vent pipe of the same diameter, terminating outside the building. The vent must terminate at least two (2) feet (0.6 m) above the highest point of the roof or other object that is within ten (10) feet (3.0 m) of the vent termination. The vent pipe must have a listed vent cap which allows a full equivalent opening for flue products (see Figure 4). The top of the vent cap must be at least five feet in vertical height above the draft hood outlet.

Type “B” double wall or equivalent vent pipe is recommended. However, single wall metal vent pipe may be used as specified in the latest edition of the National Fuel Gas Code ANSI Z223.1 or in Canada CAN/CGA-B149.1 and B149.2

IMPORTANT NOTE: Do not use sheet metal screws at the snap lock joints of Type B gas vents.

When venting multiple appliances through one common duct, each appliance must have it’s own exhaust vent temperature limit switch. All vent temperature limit switches must be wired in series so as to prevent all appliances from firing in the event that any vent opening becomes blocked. Refer to ANSI Z223.1 in the United states or CAN/CGA B149.1 or .2 for more information on multiple venting.

SECTION 4. Gas Connections

4.1 Gas Supply and Piping

Review the following general instructions before continuing the installation.

⚠ WARNING

Do not convert this heater from natural gas to propane gas, or propane to natural without manufacturer's approval. Unauthorized field conversion could create carbon monoxide gas which can cause property damage, serious injury, or death.

- Gas piping installation must be in accordance with the latest edition of ANSI Z223.1 and all local codes. In Canada, the installation must be in accordance with CAN- B149.1 or .2 and all local codes that apply.

- Check the rating plate to make sure the heater is fitted for the type of gas being used. Jandy heaters, as shipped from the factory for use in the United States and Canada, are certified to operate at altitudes shown in Table 3.

Table 3. Altitude Designations for the LJ Pool Heater

NATURAL GAS		
ALTITUDE DESIGNATION	UNITED STATES	CANADA
LOW ALTITUDE	0-3000 FT	0-2000 FT (0-610 m)
MID ALTITUDE (H)	3001-6000 FT	2001-4500 FT (611-1370 m)
HIGH ALTITUDE (J)	6001-10,000 FT	NOT APPLICABLE
LP		
LOW ALTITUDE	0-5000 FT	0-4500 FT (0-1370 m)
HIGH ALTITUDE (H)	5001-10,000 FT	NOT APPLICABLE

⚠ Caution
Permanent damage to the gas valve will occur if the following procedures are not followed.

- Use the figures in Table 4 to size the gas inlet piping from the gas meter to the heater. Check all local codes for compliance before installing the heater.

Table 4. Natural Gas Pipe Size Requirements

Heater Size	Distance from Gas Meter					
	0-50 feet (0-15 m)		50-100 feet (15-30 m)		100-200 feet (30-60 m)	
	in.	(mm)	in.	(mm)	in.	(mm)
125	3/4	(19)	1	(25)	1	(25)
175	1	(25)	1	(25)	1-1/4	(32)
250	1	(25)	1-1/4	(32)	1-1/4	(32)
325	1-1/4	(32)	1-1/4	(32)	1-1/2	(38)
400	1-1/4	(32)	1-1/2	(38)	1-1/2	(38)

Notes:

- These numbers are for natural gas (0.65 Sp. Gr.) and are based on 1/2 inch (13mm) water column pressure drop. Check supply pressure with a manometer, and local code requirements for variations. For liquefied petroleum gas, reduce pipe diameter one size, but maintain a 3/4 inch (19mm) minimum diameter.
- Check supply pressure and local code requirements before proceeding with work.
- Pipe fittings must be considered when determining gas pipe sizing.

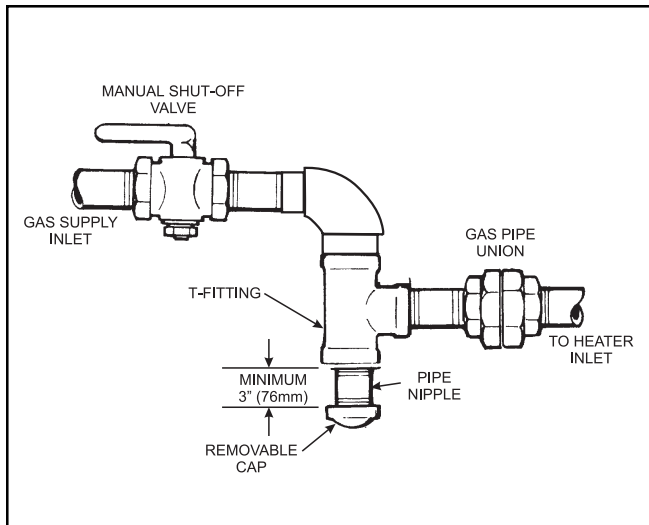

Figure 5. The proper design for a sediment trap / drip leg.

5. Install a sediment trap (drip leg) ahead of the gas controls (see Figure 5). Fit the trap with a threaded cap which can be removed for cleaning.
6. Install a manual gas shutoff valve for service and safety. Do not use a restrictive gas cock. **DO NOT USE FLEXIBLE GAS PIPING**, it will restrict the gas flow to the heater.
7. Disconnect the heater and its individual shutoff valve from the gas supply system during pressure testing of the system at pressures higher than 1/2 pounds per square inch (psi) (3.45 kilopascals [kPa]). If the test pressure is equal to or less

than 1/2 psi (3.45 kPa), close the manual shutoff valve on the heater during the piping pressure test.

8. If the gas supply pressure is less than required, check for undersized pipe between the meter and the heater, a restrictive fitting, or an undersized gas meter. Gas supply pressures to the heater are listed in Table 5.

NOTE: The maximum inlet gas pressure must not exceed the specified value. The minimum value listed is for the purpose of input adjustment. Refer to Table 5.

Table 5. Gas Supply Pressure Requirements

Supply Pressure Water Column	Natural Gas	Propane Gas
	in. (mm)	in. (mm)
Minimum	5.5 (140)	10.0 (255)
Maximum	10.0 (255)	14.0 (355)

9. Before operating the heater, test the complete gas supply system and all connections for leaks using a soap solution. Do not use an open flame.

⚠ Caution

Some leak test solutions (including soap and water) may cause corrosion or stress cracking. Rinse the piping with water after testing.

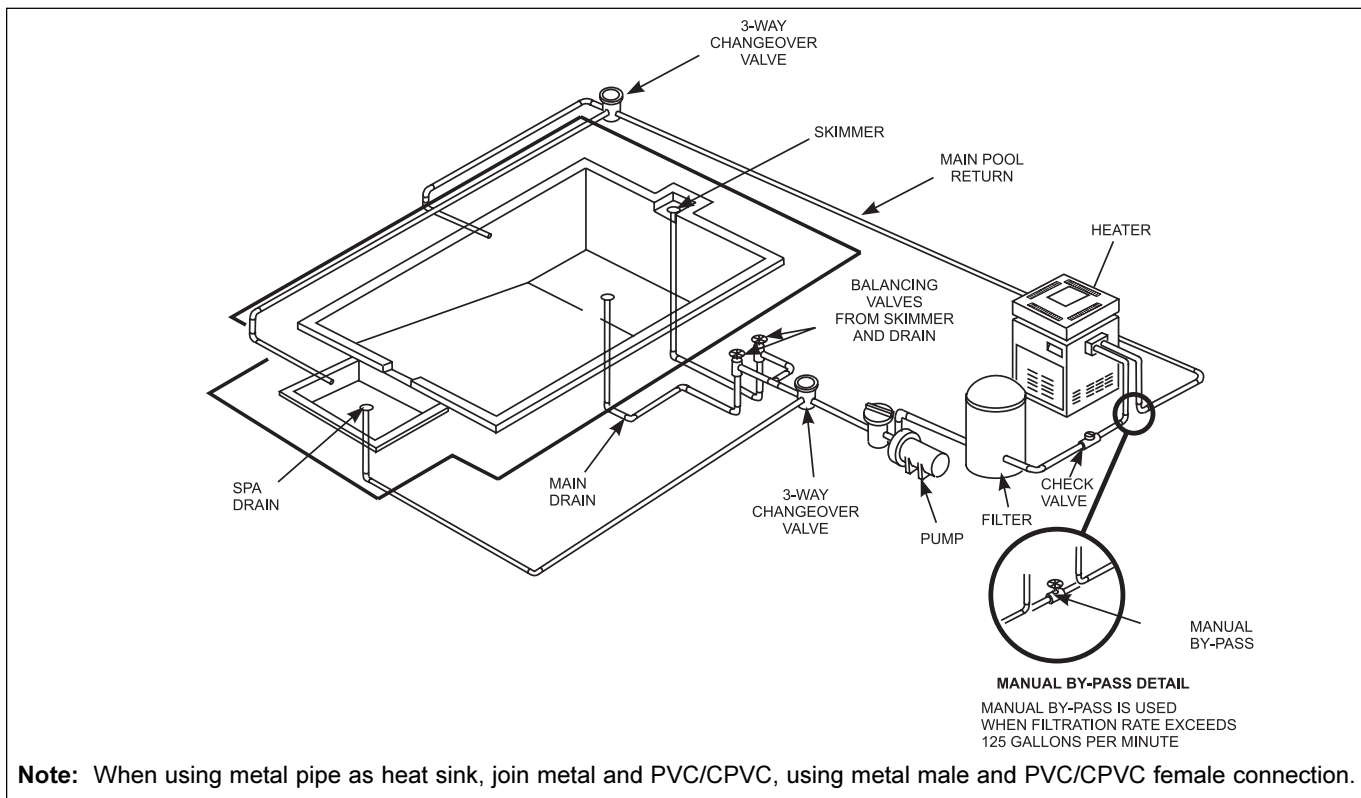

Note: When using metal pipe as heat sink, join metal and PVC/CPVC, using metal male and PVC/CPVC female connection.

Figure 6. Typical installation.

4.2. Special Precautions for Propane Gas

Liquefied petroleum (LP) gas is heavier than air. Therefore, do not install pool heaters using LP gas in pits or locations where gas might collect. Locate heaters a safe distance from LP gas storage and filling equipment. Consult local codes and fire protection authorities about specific installation restrictions.

SECTION 5. Water Connections

5.1 Water Piping

Figure 6 illustrates typical piping for pool equipment in pool/spa combination pools.

The heater must be protected from back-siphoning of water, which can result in dry starts. If there is any chance of back-siphoning, provide a check valve between the pool and the filter pump inlet.

Arrangement of pool system components other than as illustrated in these diagrams can affect the operation of the heater's water pressure switch. Location of the heater above or below the pool water surface can also affect operation of the switch. In general, the pressure switch can be adjusted to accommodate this effect if the heater water connections are no more than six feet below the pool water surface and no more than 15 feet above it. See instructions for pressure switch adjustment (Section 7.2) in the heater start-up section of this manual for more information about this.

Note that when pool equipment is located below the pool surface a leak can result in large scale water loss or flooding. Water Pik Technologies cannot be responsible for such water loss or flooding or the damage caused by either occurrence.

5.2 Check Valve Installation

For normal installations, do not install a shutoff valve or any kind of variable restriction in the water piping between the heater outlet and the pool/spa.

Install a check valve if there is any chance of back-siphoning when the pump stops. Do not install any other valve in the piping between the heater outlet and the pool, unless it is being used as a diverter valve. For special installations such as water connections below the water level of the pool, or for other questions contact the Jandy Technical Service department at (707) 776-8200 ext. 260.

5.3 Automatic Flow Control Valve

The inlet/outlet header of the Lite2 comes equipped with an automatic flow control valve. The automatic flow control valve maintains the proper flow through the heater at rates up to approximately 125 Gallons Per Minute (GPM) (475 liters per minute [LPM]). If the filter system flow rate is higher than approximately 125 GPM (475 LPM), install a manual bypass valve (see Figure 6), then perform a tempera-

ture rise test (see Section 7.7) and adjust the flow using the bypass valve until the proper temperature rise is obtained.

5.4 Reversible Water Connections

Water Pik Technologies ships the Lite2 heater with the water connections on the right side. The Lite2 heater can be installed with the water connections on either side. It could be necessary, or helpful, to switch the connections to the left side to improve access for installation and service. Perform this modification before installing the heater using the following procedures:

1. Remove heater door.
2. Remove all 8 hex-head screws fastening the top and lift the top assembly straight up (see Figure 7).

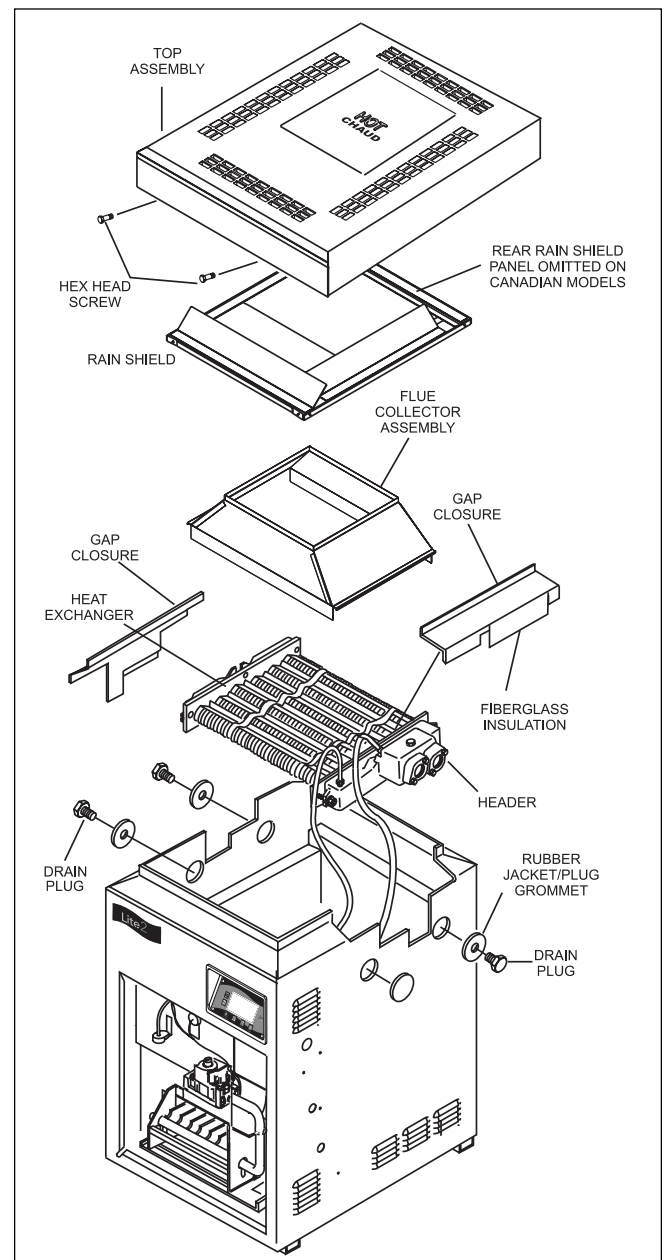

Figure 7. Heat exchanger reversal.

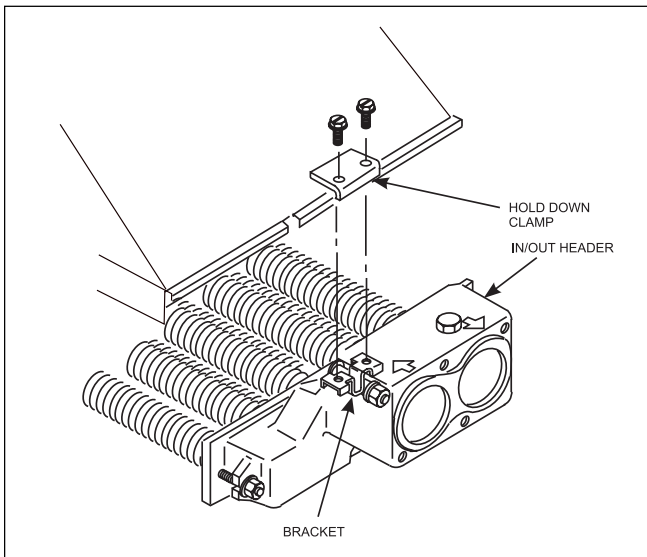

Figure 8. Flue collector hold-down brackets.

3. Remove rain shield assembly and set it aside.
4. Remove screws that fasten the gap closures to the jacket and put them aside. Remove gap closures.
5. Remove the screws securing the two flue collector hold down clamps and remove the clamps (see Figure 8). Remove flue collector.
6. Remove the three rubber jacket/plug grommets and drain plugs (see Figure 7). One is located under the water connections on the right side. The other two are on the left side of the heater.
7. Tag and disconnect the white wire on the pressure switch (PS) and the white wire from the fusible link.
8. Remove plastic tie wraps and pull the white wires out of the front compartment through the vestibule cover and coil them on the heat exchanger.

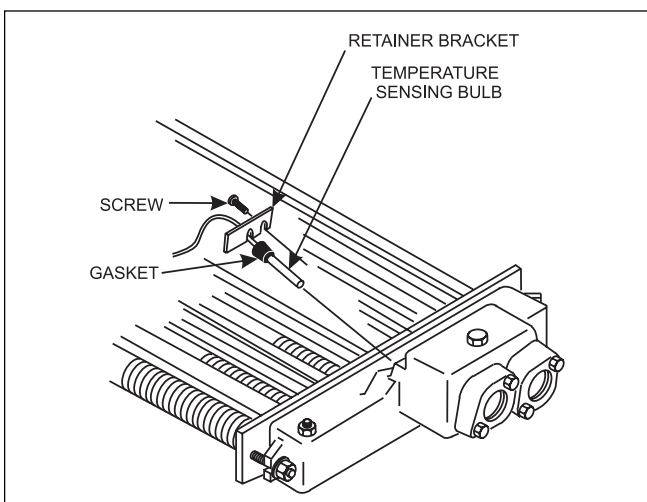

Figure 9. Temperature sensing bulb.

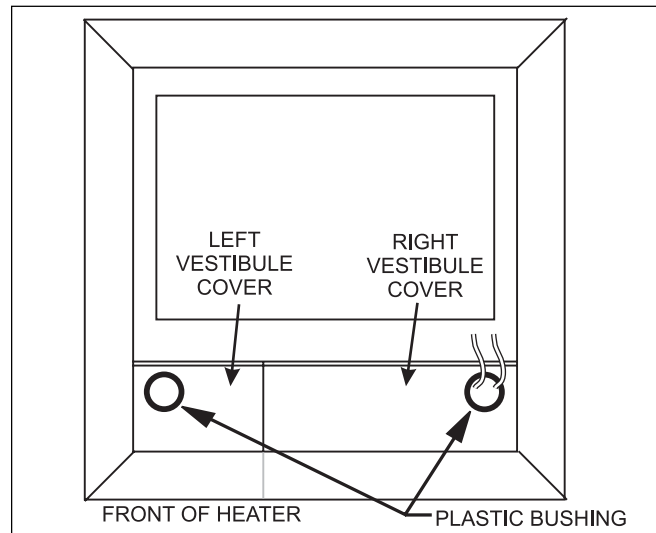

Figure 10. Vestibule covers.

9. Unscrew the brass compression fitting securing the pressure switch to the inlet/outlet header. Remove tube from header and gently bend it out of the way.
10. Loosen the screw securing the temperature sensing bulb retainer bracket. Slide the retainer bracket off the bulb flange and remove the bulb from the header (see Figure 9). Pull pressure switch tube through the hole in the vestibule cover and into the vestibule (controls compartment), then pull the thermostat bulb assembly through same hole (see Figure 10).

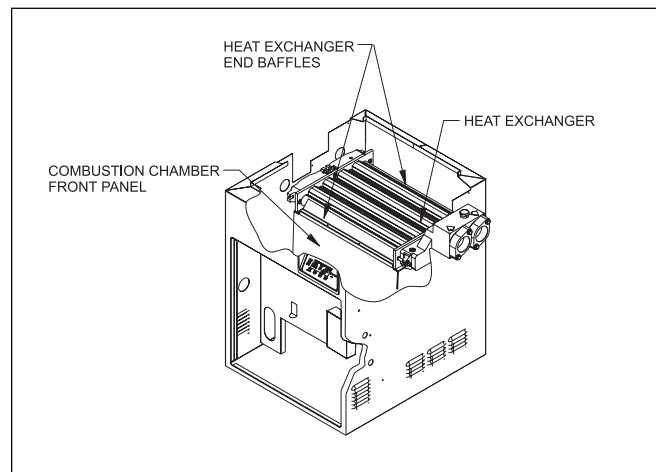

Figure 11. Heat exchanger and end baffles.

11. When removing the heat exchanger from the heater (sizes 125, 175 and 250 only), the end baffles of the heat exchanger must be removed. There are two baffles covering part of the front and rear tubes of the heat exchanger. Each baffle is held in place by two screws which mount to the top of the combustion chamber wall. Remove the screws and the baffles before attempting to lift the heat exchanger out of the heater (see Figure 11).

⚠ Caution

It may be necessary to have help lifting the heat exchanger out and replacing it.

12. Lift the heat exchanger assembly out of the heater. Reinstall heat exchanger 180 degrees (inlet/outlet header left) from its original position.
13. After replacing the heat exchanger into the heater, the end baffles must be replaced. Each one is held in place by two screws which mount to the top of the combustion chamber wall. Reinstall the baffles on the front and rear of the heat exchanger before continuing with the "Reversible Water Connections" procedure.
14. Remove pressure switch retainer (plastic cable clamp) from the inner panel (allow pressure switch to float).
15. Reroute pressure switch tube and thermostat bulb assembly through hole in left side of vestibule cover in reverse order. Relocate the pressure switch tube and temperature sensor through the open side of the vestibule.
16. Reinstall the temperature sensing bulb in the header, and fasten it with the retainer bracket and screw.
17. Reinstall the compression fitting at the end of the pressure switch tube into inlet/outlet header and tighten the fitting.
18. Route the white wiring from the high limit switches beside the heat exchanger and down to the original location following the pressure switch tubing. Secure white wires to the pressure switch tube with plastic wire ties.
19. Connect the white wire labeled PS to the pressure switch and the other white wire to its original location on the fusible link.
20. Reinstall the drain plugs and tighten securely. Replace jacket/plug grommets.
21. Install the flue collector assembly. Be sure the front and rear panels of the flue collector are installed into the grooves on the front and rear combustion chamber heat shield panels. Be sure the sheet metal panels are not pinching any wires.
22. Attach the flue collector hold down clamps to the clips located under the two center header bolts.
23. Replace the gap closures and tighten the screws securely. Be sure to replace the insulation, completely covering the temperature sensor. Insulation must be a minimum of 1" thick.

24. Double-check to make sure the wiring is not pinched against sharp edges, or resting on the flue collector assembly.
25. Reinstall rain shield assembly.
26. Replace the top assembly. Make sure the tabs are outside the heater jacket. Fasten the top assembly with the hex-head screws.
27. Install plastic tie wraps on wiring in the vestibule (controls compartment).
28. Install heater door.

5.5 Connections at Heater

The heater has 2" NPT universal header couplings. You can connect threaded 2" NPT iron pipe, unthreaded 1-1/2" iron pipe, 1-1/2" or 2" copper pipe without an adapter (see Figure 12).

Plastic piping (PVC Schedule 40) can be connected to the heater if local codes allow it, by using the CPVC nipples included with your heater.

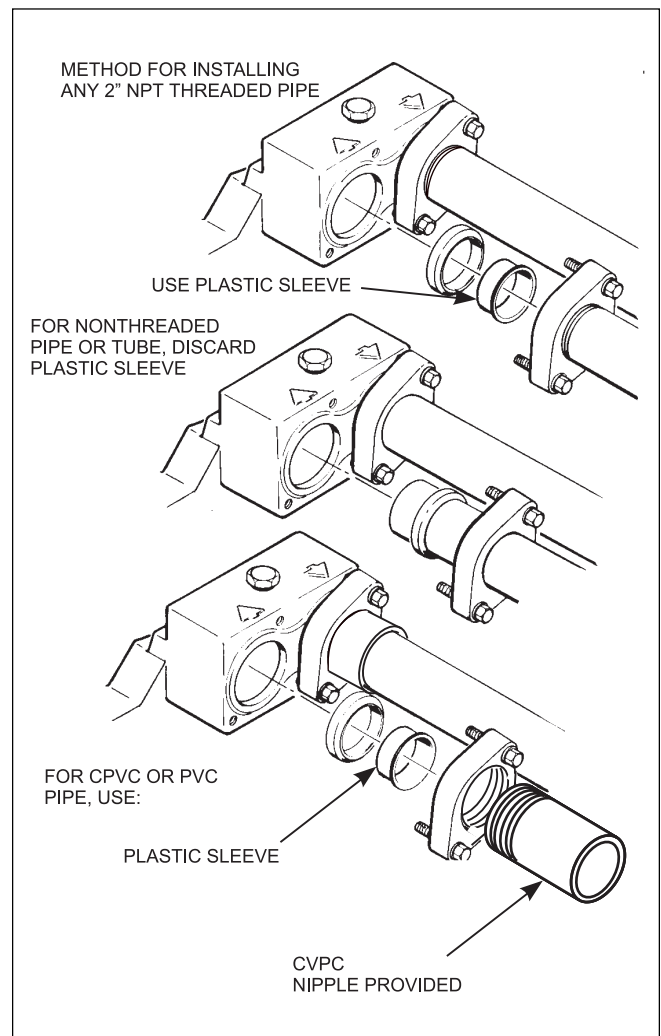

Figure 12. Piping installation.

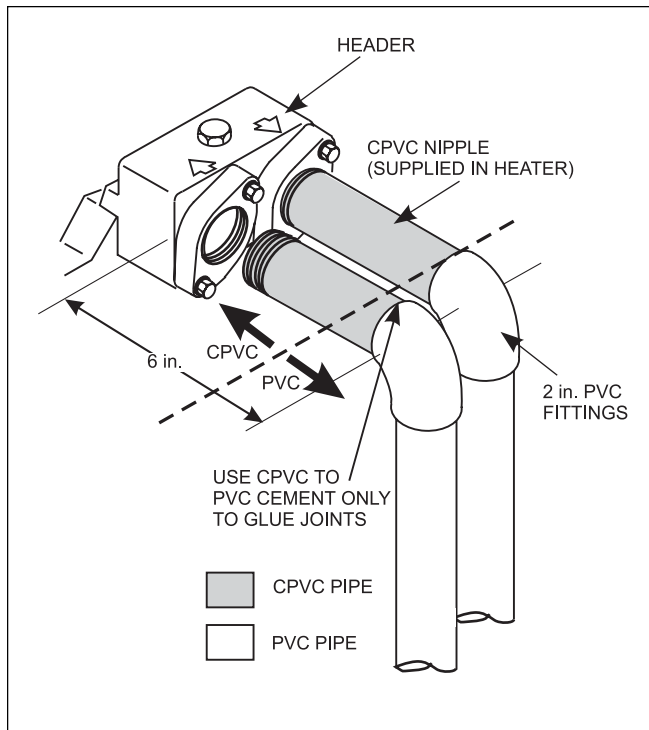

Figure 13. Plastic piping connections.

To install plastic piping (see Figure 13):

1. Remove CPVC nipples from plastic bag.
2. Screw CPVC nipples into metal flange until tight, using Teflon tape on plastic threads.
3. Prepare the end of the pipe with the proper adapter, PVC/CPVC primer and glue. Follow the manufacturer's instructions provided with the primer and glue for preparation procedures and curing times.

5.6 Pressure Relief Valve

A pressure relief valve (PRV) is recommended in all installations and is mandatory in any installation in which the water flow can be shut off between the heater outlet and the pool/spa.

A pressure relief valve is not supplied with the heater. However, it may be required by local codes. The pressure rating of the valve should be at or below the lowest working pressure of any component in the filter system. Any pressure relief valve installed must comply with provisions of the Standard described in ANSI Z21.22 for the United States, or CAN1-4.6 in Canada.

To install a pressure relief valve, do the following:

1. Remove the 3/4 inch (19 mm) brass plug located on the top of the inlet/outlet header (see Figure 14).

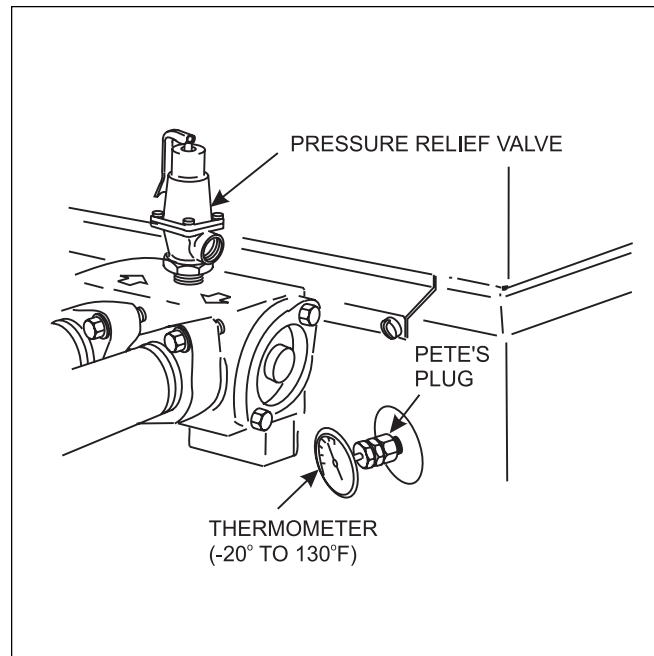

Figure 14. Thermometer and pressure relief valve.

2. Install the pressure relief valve in the threaded hole from which the plug was removed.
3. Be sure that the exhaust port of the PRV is plumbed so that any hot water is directed safely away from any public areas and away from any area occupied during servicing.

5.7 Auxiliary Components, Chlorinators, Ozone Generators, and Sanitizing Chemicals.

The Lite2 heater is manufactured with materials that are not compatible with high concentrations of ozone, chlorine, bromine, or other sanitizing chemicals. Heater damage caused by excessive chemicals or improper ozonization is not covered by the Water Pik Technologies, Inc. warranty. Be sure to adhere to the following:

- When ozone is injected upstream of the heater, install an offgas mixing chamber, or an ozone bypass system between the heater and the ozone injector to prevent ozone and air from entering the heater.
- When chemical feeders are used, plumb the feeder downstream of the heater and install an in-line check valve between the heater and the feeder (a minimum of 18" is required between the heater and the check valve).
- Never deposit chemicals directly in the pool skimmer.

SECTION 6. Electrical

⚠ Caution

Label all wires prior to disconnection when servicing controls. Wiring errors can cause improper and dangerous operation. Verify proper operation after servicing.

⚠ Attention

Au moment de l'entretien des commandes, étiquetez tous les fils avant de les débrancher. Des erreurs de câblage peuvent entraîner un fonctionnement inadéquat et dangereux.

6.1 General Information

Wiring connections must be made exactly as shown in the wiring diagram found on the inside of the heater (see Figure 15a) . The heater must include a definite means of grounding. There is a bonding lug on the right side of the heater, where a bond wire must be attached.

The LJ heater controller has a built-in time clock to run the pump, so an external time clock is not needed. To utilize the internal time clock, the power for the pump must be wired through the heater. A separate relay must be added to correctly wire the power to the pump. The relay may be purchased from your local Jandy distributor. Water Pik Technologies recommends the use of Jandy part number R0658100 because it is supplied with the wire harness that is needed to connect the relay to the power circuit board.

6.2 Main Power

Electrical wiring must be in accordance with the latest edition of the National Electric Code (NEC), ANSI/National Fire Protection Association (NFPA) 70, unless local code requirements indicate otherwise.

The heater comes factory-wired intended for use with 230 Volt, 60 Hz AC field electrical supply. To use 115 Volt, 60 Hz AC requires a different wiring configuration for the pump. This must be done by a certified electrician only, as with all wiring. To wire the heater and pump for 115V, 60 Hz AC, follow the alternate 115V wiring method depicted in Figure 15. The ends of the power conversion plug are color coded. The blue end of the plug is intended for use with a 230 VAC power supply and the white end of the plug is intended to be used with a 115 VAC power supply. The power conversion plug on the power circuit board (see Figure 15) must be removed from the board, the plastic stop pin must be removed from the white end of the plug and placed into a

connection on the blue end of the plug, and then the white end inserted into the receptacle on the power circuit board. This will convert all power in the heater to 115 VAC.

To wire the Lite2 model LJ heater to a 115 V or 230 V / 60 Hertz (Hz) electrical source:

1. Be sure that the power supply to the heater is off.
 2. Remove the door of the heater.
 3. Remove the screws that hold the cover to the power connection box located in the upper right corner of the heater. Remove the cover.
 4. Check the power conversion plug to be sure that the correct side is plugged into the power circuit board to match the voltage supplied to the heater. Each side of the plug is labeled accordingly.
- NOTE:** The blue side of the power conversion plug is used for 230V and the white side is used for 115 V.
5. Remove and discard the red and black test leads that are connected to the "Power In" terminals on the power circuit board.
 6. Run the wires from the power source through the hole on the right side of the heater. Connect the wires to the "Power In" terminals on the power circuit board. The connection will be made inside the heater and enclosed in the power connection box (see Figure 16). Be sure to follow the wiring diagram on page 16 to configure the power for the correct input voltage.
 7. Attach the ground wire to one of the green ground screws located on the back panel of the power connection box.
 8. Replace the cover of the power connection box and replace the screws to hold it in place.
 9. Connect a bonding wire (8 ga copper) to the bonding lug on the right side of the heater.

NOTE: No external junction box is required. Conduit may be connected directly to the jacket of the heater. Low voltage wires (24V) that stay inside the heater must exit the connection box through the upper hole provided on the left side of the box. High voltage wires (115/230V) that stay inside the heater must exit the connection box through the lower hole provided on the left side of the box.

LITE2 MODEL LJ WIRING CONNECTION DIAGRAM

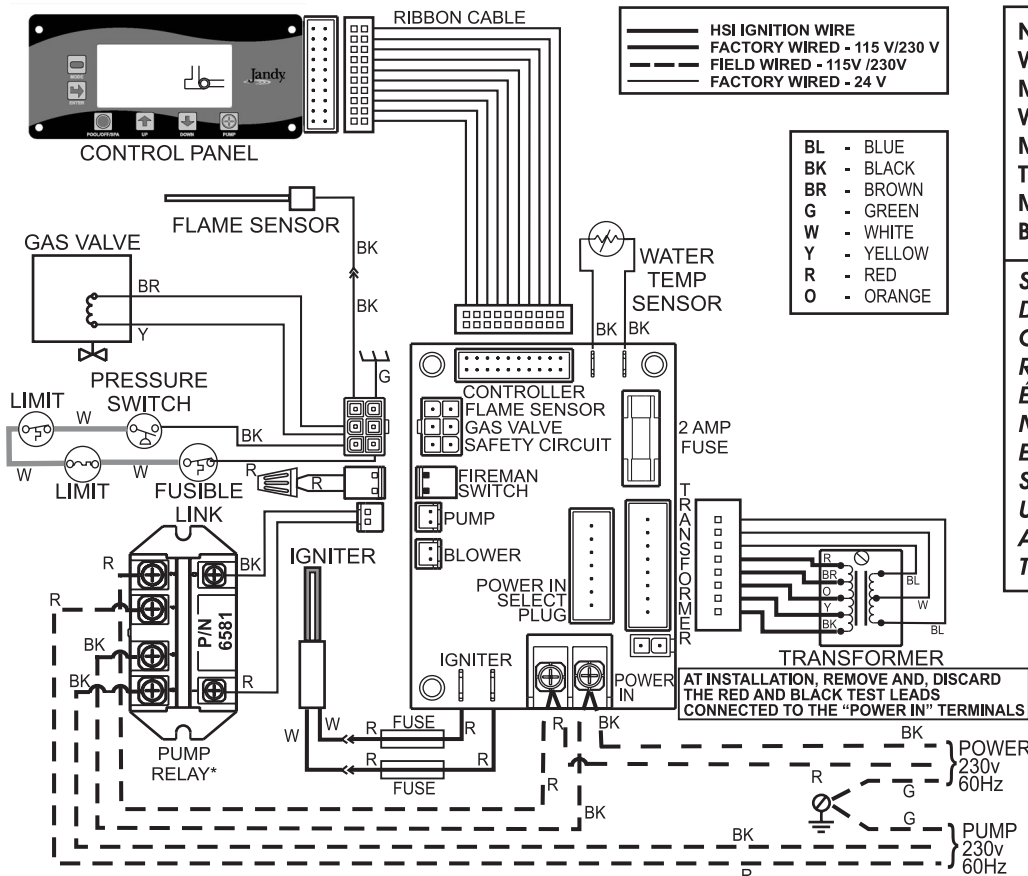

NOTES: IF ANY OF THE ORIGINAL WIRE AS SUPPLIED WITH THE HEATER MUST BE REPLACED, APPLIANCE WIRING MATERIAL RATED FOR 105°C MUST BE USED. WHERE MARKED THUS , APPLIANCE WIRING MATERIAL RATED FOR 200°C MUST BE USED.

SI L'UN QUELCONQUE DES FILS D'ORIGINE FOURNIS AVEC LE CHAUFFE-EAU DOIT ÊTRE REMPLACÉ, UN FIL POUR APPAREILS ÉLECTRIQUES À TOLÉRANCE NOMINALE DE 105°C DOIT ÊTRE EMPLOYÉ. SI LE FIL PORTE LE SYMBOLE , LE REMPLACER UNIQUEMENT PAR UN FIL POUR APPAREILS ÉLECTRIQUES À TOLÉRANCE NOMINALE DE 200°C.



waterpik
Technologies, Inc.

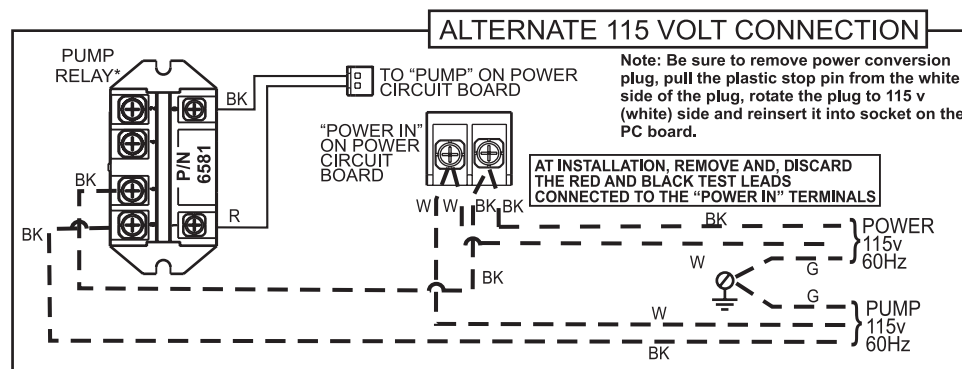

A) Connection Diagram

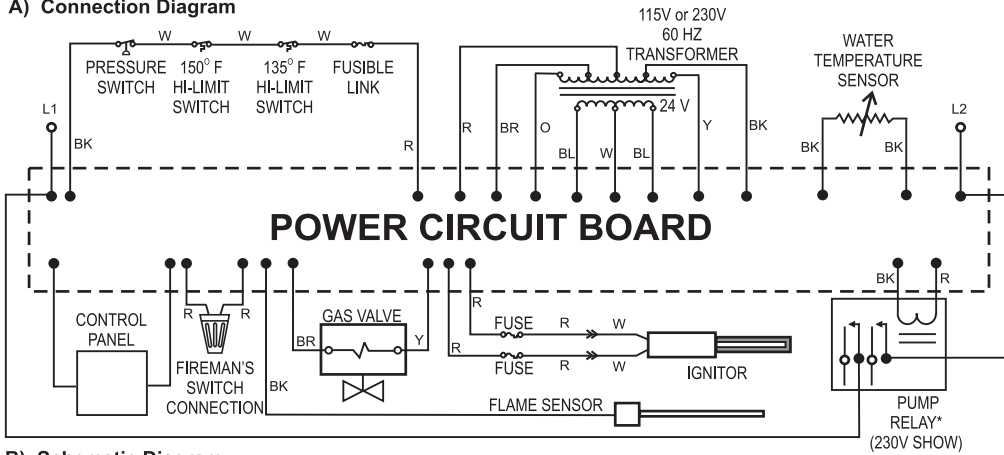

B) Schematic Diagram

*Optional pump relay (Jandy P/N R0658100) needed when connecting pump to LJ controller time clock.

Figure 15. Wiring Connection Diagram and Schematic Diagram

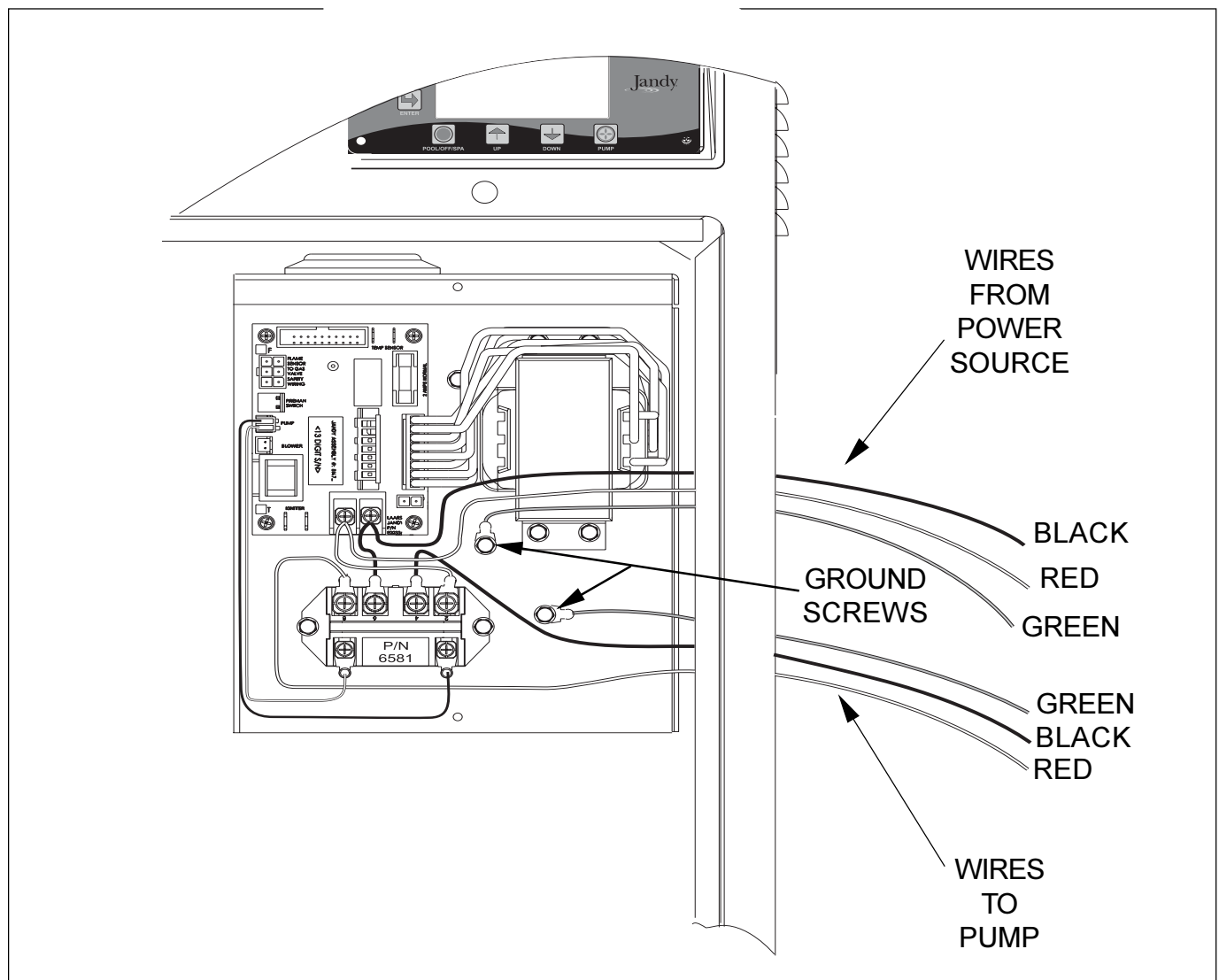

Figure 16. Field Wiring Connections (230V Shown).

6.3 Bonding

⚠ Caution

This heater must be connected to a bonding grid with a solid copper wire not smaller in diameter than 8 ga.

The National Electrical Code and most other codes require that all metallic components of a pool structure, including reinforcing steel, metal fittings and above ground equipment be bonded together with a solid copper conductor not smaller than a number 8 wire. The heater, along with pumps and other such equipment must be connected to this bonding grid. A special labeled bonding lug is provided on the right side of the heater to accommodate this requirement.

6.4 Pump Power Connection

Electrical wiring must be in accordance with the latest edition of the National Electric Code (NEC), ANSI/National Fire Protection Association (NFPA) 70, unless local code requirements indicate otherwise.

To connect the pump to the LJ controller internal time clock perform the following steps.

1. Turn off all power to the heater at the circuit breaker panel.
2. Remove the door of the heater.
3. Remove the screws that hold the cover to the power connection box located in the upper right corner of the heater. Remove the cover.
4. Install the relay (Jandy part number R0658100) in the mounting holes provided in the power connection box (See Figure 16). The relay must be installed so that it is protected by the power connection box cover when it is replaced.
5. Install the wire harness (assembled to the relay, Jandy part number R0658100). Check that the black wire connects to terminal "0" of the relay and the red wire connects to terminal "1". Plug the other end of the harness into the power circuit board at the connection labeled "Pump Relay".

6. Remove the button plug from the hole on the right side of the heater located just below the entry hole for the power.
7. Feed the pump wires through the jacket and connect them to the "Power In" terminals (on the power circuit board) and the relay terminals as indicated on the wiring diagram on page 16. Remember to use the alternate wiring scheme shown on page 16 when connecting power to a 115 volt source.
8. Attach the ground wire to one of the green ground screws located on the back panel of the power connection box.
9. Replace the cover of the power connection box and replace the screws to hold it in place. Be sure that the power wires and pump wires are completely enclosed by the cover. Be sure that the wires are not pinched by the cover.

SECTION 7. Operating Instructions

7.1 Start-Up

Be sure that there is water in the pool and that the surface level is above the skimmer or other inlet of the pool's filter system.

With any new pool or spa installation, operate the filter pump with the heater off long enough to completely clean the water. This will remove any installation residue from the water. Clean the filter at the end of this operation before starting the heater. When raising the temperature of a cold pool, program the time clock to turn the pump off 23 hours and 58 minutes after the start time (i.e. If start time is 2:00 PM then set stop time at 1:58 PM.) This lets the filter system and heater operate continuously until the water reaches the temperature setting on the temperature control. When that happens, the heater will automatically shut off, but the filter pump will keep running.

IMPORTANT: The temperature controls cannot be calibrated in the field. If the control is faulty, shut down the heater by following the procedures in Section 7.3 and have a qualified service technician replace the control. DO NOT use the thermostat switch to completely shut down the heater.

CAUTION

Do not use this heater if any part has been under water. Immediately call a qualified service technician to inspect the heater and replace any part of the control system and any gas control which has been under water.

ATTENTION

N'utilisez pas cet appareil s'il a été plongé dans l'eau, même partiellement. Faites inspecter l'appareil par un technicien qualifié et remplacez toute partie du système de contrôle et toute commande qui ont été plongés dans l'eau.

CAUTION

Should overheating occur or the gas supply fail to shut off, turn off the manual gas control valve to the heater.

ATTENTION

En cas de surchauffe ou si l'alimentation en gaz ne s'arrête pas, fermez manuellement le robinet d'arrêt de l'admission de gaz.

CAUTION

Do not attempt repairs on the gas controls or appliance. Tampering is dangerous and voids all warranties.

CAUTION

Keep all objects off the top of the heater. Blocking air flow could damage the heater, and may void the warranty.

WARNING

Vent pipes, draft hoods, and heater tops get hot! These surfaces can cause serious burns. Do not touch these surfaces while the heater is in operation. Adding a vent cap reduces the temperature on the top.

WARNING

For your safety, when starting the heater, keep your head and face well away from the lower firebox opening to prevent any risk of personal injury.

7.2 Setting the LJ Controller Functions and Limits

The LJ controller is a microprocessor based controller designed to control various functions of your pool and spa water circulation system. It provides a visual display of the status of the heater and pump functions. It has a built-in time clock that eliminates the need for an external clock to control the pump. It even provides information in the form of service codes used to diagnose a problem in the event of a malfunction. The pressure sensitive push-button keypad and large LCD display make the controller easy to program and use.

When the LJ controller is powered for the first time, it recognizes that the installation is new and uses all the internal default values for control. On initial start-up and any time the power to the heater has been interrupted and then reestablished, the firmware revision will flash for one second on the display screen where the time is normally displayed. After one second, the display will show the time. The following sections explain how to set your heater control to your preferences. After programming the controller for the first time, all settings and modes will remain in memory until changed. Even if the power to the heater is interrupted, the settings will not have to be reprogrammed. If the pump and heater were on when the power went off, they will be on when power is restored to the heater. The only indication that power to the heater has been interrupted is that the 'real time' clock will be flashing. When power is restored the clock will remember the time when the power went off and resume from that point on. Therefore, the clock will have to be reset. Refer to Figure 17 to identify the location of keys and display items mentioned in the following sections.

NOTE: All of the functions and limits of the LJ controller can be reset to factory default values by pressing and holding the ENTER key for 7 seconds.

HOLD FOR 7 SECONDS
TO RESET TO FACTORY
DEFAULT VALUES

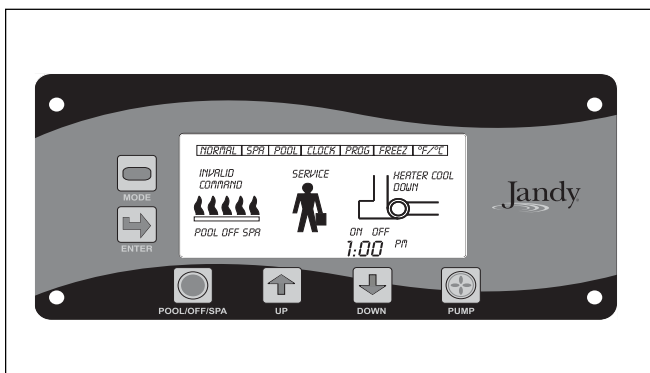
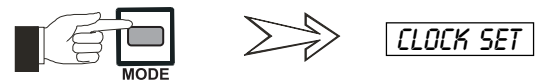

Figure 17. LJ Controller and Display

7.2.1 Setting the Real Time Clock

The 'REAL TIME CLOCK' displays the current time. When the heater is powered for the first time the controller will show a flashing display of 1:00 (PM). Any subsequent start-ups after a power interruption will cause the display to flash the time that the power went off. It is important to reset the 'REAL TIME CLOCK' anytime the power to the heater has been interrupted so that the 'PUMP TIME CLOCK' operates the pump at the desired times. To set the 'REAL TIME CLOCK' perform the following steps:

1. Press the MODE key repeatedly until the words 'CLOCK SET' appear at the top of the display screen.



2. Press the ENTER key. The hour indicator in the lower right corner of the display will start to flash.



3. Press the UP or DOWN key to adjust the hour. The PM indicator shows for PM time. There is no indicator for AM time.



4. When the hour is set correctly, press the ENTER key. The minutes indicator will start to flash.



5. Press the UP or DOWN key to adjust the minutes.



6. When the minutes are set correctly, press the ENTER key. The minutes indicator will stop flashing and the word 'NORMAL' will appear in the upper left corner of the display screen to indicate that the time has been set and the heater is now in normal operating mode.

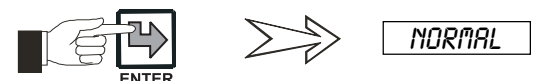

7.2.2 Setting the Temperature Scale

The LJ controller can display all temperature readings in either degrees Fahrenheit or degrees Centigrade. Once the temperature scale is entered, it may take up to 30 seconds to update the inlet water temperature. To set the display to the desired 'TEMPERATURE SCALE' perform the following steps:

1. Press the MODE key repeatedly until the icon '°F/°C' appears at the top of the display screen.

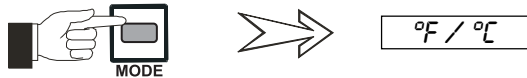

2. Press the ENTER key. The temperature scale indicator in the lower left corner of the display will start to flash.



3. Press the UP or DOWN key to toggle between °F and °C.



4. When the temperature scale is set to your preference, press the ENTER key. The temperature scale indicator will stop flashing and the word 'NORMAL' will appear in the upper left corner of the display screen to indicate that the desired temperature scale has been set and the heater is now in normal operating mode.

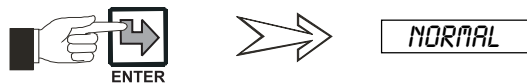

7.2.3 Setting Pool and Spa Temperatures

The LJ controller has dual temperature modes, which allows two different temperature settings, selected by the SELECTION key on the bottom of the control panel. One mode can be set for normal use and the other for standby; or one can be set for pool and the other for a spa. This feature makes it easy to switch between heating the pool and heating the spa by eliminating the need to change the thermostat setting to the desired temperature each time the switch is made.

NOTE: The temperature set range for both the 'POOL' and 'SPA' settings is 70°F (21°C) to 104°F (40°C). If an attempt is made to set a temperature outside of this range, the words 'INVALID COMMAND' will appear on the left side of the display.

To set the 'POOL WATER TEMPERATURE' perform the following steps:

1. Press the MODE key repeatedly until the words 'POOL SET' appear at the top of the display screen.

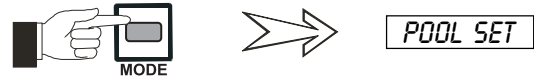

2. Press the ENTER key. The temperature indicator in the lower left corner of the display will start to flash.



3. Press the UP or DOWN key to adjust the desired temperature.



4. When the temperature is set to your preference, press the ENTER key. The temperature indicator will stop flashing and the word 'NORMAL' will appear in the upper left corner of the display screen to indicate that the desired pool temperature has been set and the heater is now in normal operating mode.

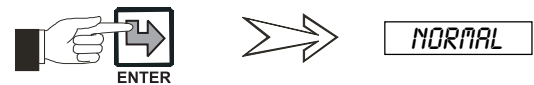

To set the 'SPA WATER TEMPERATURE' perform the following steps:

1. Press the MODE key repeatedly until the words 'SPA SET' appear at the top of the display screen.

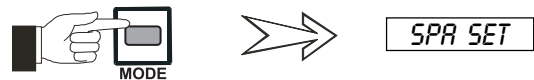

2. Press the ENTER key. The temperature indicator in the lower left corner of the display will start to flash.



3. Press the UP or DOWN key to adjust the desired temperature.



- When the temperature is set to your preference, press the ENTER key. The temperature indicator will stop flashing and the word 'NORMAL' will appear in the upper left corner of the display screen to indicate that the desired spa temperature has been set and the heater is now in normal operating mode.



7.2.4 Setting the Freeze Temperature

The pump must be controlled by the heater's internal time clock for the freeze protection to operate. The LJ controller will protect your pool and spa equipment from damage due to freezing for short periods of time. Once the 'FREEZE TEMPERATURE' is set and the heater is in the 'OFF' mode, the pump will automatically start when the water temperature drops to the 'FREEZE TEMPERATURE'. The pump will shut off when the water has warmed to 2° above the 'FREEZE TEMPERATURE'.

NOTE: The temperature set range for the 'FREEZE TEMPERATURE' is 34°F (1°C) to 42°F (5°C). If an attempt is made to set a temperature outside of this range, the words 'INVALID COMMAND' will appear on the left side of the display.

To set the heater to the desired 'FREEZE TEMPERATURE' perform the following steps:

- Press the MODE key repeatedly until the words 'FREEZE SET' appear at the top of the display screen.

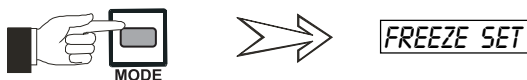

- Press the ENTER key. The temperature indicator in the lower left corner of the display will start to flash.

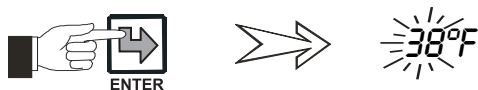

- Press the UP or DOWN key to adjust the desired temperature.



- When the temperature is set to your preference, press the ENTER key. The temperature indicator will stop flashing and the word 'NORMAL' will appear in the upper left corner of the display screen to indicate that the desired freeze temperature has been set and the heater is now in normal operating mode.

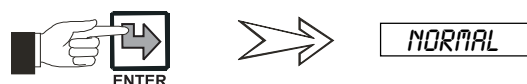

7.2.5 Setting the Pump Time Clock

The LJ controller has a built-in 'PUMP TIME CLOCK'. An optional electrical relay must be installed to use this function of the heater. The time clock may be set to cycle the pump once in each 24 hour period. To set the 'ON' and 'OFF' times for the 'PUMP TIME CLOCK' perform the following steps:

- Press the MODE key repeatedly until the icon 'PROGRAM' appears at the top of the display screen.



- To program the start time of the pump, press the ENTER key. The hour indicator in the lower right corner of the display will start to flash and the word 'ON' will appear over the hour indicator.



- Press the UP or DOWN key to adjust the hour. The PM indicator shows for PM time. There is no indicator for AM time.



- When the hour is set correctly, press the ENTER key. The minutes indicator will start to flash.

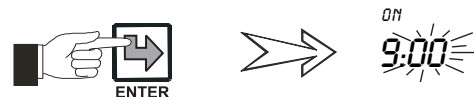

- Press the UP or DOWN key to adjust the minutes.



- When the minutes are set correctly, press the ENTER key to program the stop time for the pump. The hour indicator in the lower right corner of the display will start to flash and the word 'OFF' will appear over the minutes indicator.



- Press the UP or DOWN key to adjust the hour. The PM indicator shows for PM time. There is no indicator for AM time.



- When the hour is set correctly, press the ENTER key. The minutes indicator will start to flash.



- Press the UP or DOWN key to adjust the minutes.



- When the minutes are set correctly, press the ENTER key. The minutes indicator will stop flashing and the word 'NORMAL' will appear in the upper left corner of the display screen to indicate that the pump time clock has been set and the heater is now in normal operating mode.



7.3 Lighting and Shutdown Procedures

Before starting your heater be sure that all of the functions and limits of the LJ Controller have been set according to the previous section of this manual (Section 7.2, "Setting the LJ Controller Functions and Limits"). Once the controls are set to your preferences, follow the instructions outlined on the following page. **Read and follow all safety instructions first.**

A more detailed set of instructions of the operation of the LJ Controller follows in the next section.

NOTE: If your LP tank runs out of fuel, turn off gas at the heater. After the tank is refilled, the heater must be relit following the instructions found on the inside of the heater. A copy of these instructions appear on the following page. **DO NOT** attempt repairs on the gas control or heater. Tampering is dangerous and voids all warranties.

7.4 Heater/Controller Operation

When the heater is shipped from the factory, the LJ controller has been tested and default values have been entered for all values in the controller memory. All values in the memory of the controller may be reset to the default values at any time by depressing and holding the 'ENTER' key for at least 7 seconds. Default values are listed in Table 6.

Before starting your heater be sure to read and become familiar with the Lighting and Shutdown instructions in the previous section. Instructions are also located on the inside of the heater.

Table 6. LJ Controller Default Settings

CONTROLLER PARAMETERS	DEFAULT VALUES
Real Time CLOCK Setting	1:00 (PM)
SPA Temperature Setting	102°F
POOL Temperature Setting	80°F
FREEZE Temperature Setting	38°F
Temperature Scale Setting (°F/°C)	°F
Pump Time Clock (PROGRAM)	8:00 AM
Heater Status	OFF
Pump Status	OFF

7.4.1 Normal Operation

Be sure that the 'NORMAL' icon is displayed in the upper left corner of the LJ Controller display screen. If it is not, depress the MODE key repeatedly until the icon appears.



The heater is now in the normal operating mode. Press the SELECT key repeatedly to toggle between the 'POOL', 'SPA', and 'OFF' settings until either the 'POOL' or 'SPA' icon appears above the temperature reading.

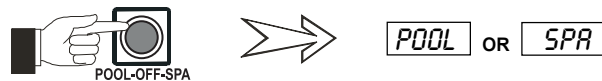

If set to 'POOL', the pool temperature setting will determine the temperature limit of the water. If set to 'SPA', the spa temperature setting will determine the temperature limit of the water.

The heater is now set to come on when the pump is running (between the programmed pump time clock "ON" and "OFF" settings), and when there is a call for heat (the inlet water temperature is more than 1° less than the chosen temperature setting).

If these two conditions are met, the controller will attempt to light the heater.

When the heater lights and the controller senses flame at the burners, the 'FLAME' icon will appear on the left side of the controller display above the temperature reading.

If the heater fails to ignite, it will attempt the ignition two more times. If the heater fails to ignite after the third try, the controller will lock out any further attempts to light the heater. The controller will show the service code 'FL 2' where the temperature reading would normally be seen and the service icon





will appear in the center of the display (see Section 9.2.1 "SERVICE CODES").

FOR YOUR SAFETY READ BEFORE OPERATING

⚠ WARNING: If you do not follow these instructions exactly, a fire or explosion may result, causing property damage, personal injury or loss of life.

- A. This appliance does not have a pilot light. It is equipped with an ignition device which automatically lights the heater. Do NOT try to light the burners by hand.
- B. BEFORE OPERATING, smell all around the appliance area for gas. Be sure to smell next to the floor because some gas is heavier than air and will settle on the floor.
- WHAT TO DO IF YOU SMELL GAS**
- Do not try to light any appliance
 - Do not touch any electric switch; do not use any phone in your building.
 - Immediately call your gas supplier from a neighbor's phone. Follow the gas supplier's instructions.
- C. If you cannot reach your gas supplier, call the fire department.
- C. Use only your hand to push in or turn the gas control knob. Never use tools. If the knob will not push in or turn by hand, don't try to repair it, call a qualified service technician. Force or attempted repair may result in a fire or explosion.
- D. Do not use this appliance if any part has been under water. Immediately call a qualified service technician to inspect the appliance and to replace any part of the control system and any gas control which has been under water.

OPERATING INSTRUCTIONS

1. STOP! Read the safety information above on this label.
2. Set the thermostat for "Pool" and "Spa" to 70° F (21°C) and the controller mode to "OFF".
3. Turn off all electric power to the appliance.
4. This appliance is equipped with an ignition device which automatically lights the heater. Do not try to light the burners by hand.
5. Remove the heater door.
6. Turn gas control knob clockwise  to "OFF".
7. Wait five (5) minutes to clear out any gas. Then smell for gas, including near the floor. If you smell gas, STOP! Follow "B" in the safety information above on this label. If you don't smell gas, go to next step.
8. Turn gas control knob counterclockwise  to "ON".
9. Replace control access panel
10. Turn on all electric power to appliance.
11. Set thermostat to desired settings for "Pool" and "Spa" and change the controller mode from "OFF" to either "POOL" or "SPA".
12. If the appliance will not operate, check that the filter pump is on, the filter is clean and water is flowing to the pool. Otherwise, follow the instructions "To Turn Off Gas To Appliance" and call your service technician or gas supplier.

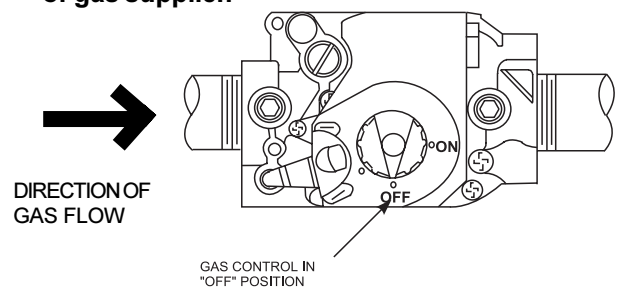

TO TURN OFF GAS TO APPLIANCE

1. Set the thermostat for "Pool" and "Spa" to 70°F(21°C) and the controller mode to "OFF"
2. Turn off all electric power to the appliance if service is to be performed.
3. Turn gas control knob clockwise  to "OFF".
4. Replace control access panel.

The controller also checks the power supply voltage. If the voltage is insufficient to run the heater properly (brown out condition), the controller will display the service code 'FL 5' and the service icon (see Section 9.2.1 "SERVICE CODES").

When the controller is in the 'NORMAL' mode, the heater will operate whenever the 'POOL' or 'SPA' mode is chosen via the SELECT key,  the pump is on and there is a call for heat. Between the programmed "ON" and "OFF" times set for the pump time clock, the heater will operate automatically if in the 'POOL' or 'SPA' mode. Outside of the programmed "ON" and "OFF" times set for the pump time clock, the pump must be turned on by pressing the 'PUMP' key. If not using the LJ controller pump time clock, the external time clock must first be activated.

7.4.2 Pump Operation

When the controller is in the 'NORMAL' mode, the pump will operate between the programmed "ON" and "OFF" times set for the pump time clock. If using an external time clock, it must be synchronized with the LJ controller time clock. Set the external time clock to start the cycle 5 minutes before the programmed "ON" time for the LJ controller pump time clock and to end the cycle 5 minutes after the programmed "OFF" time for the LJ controller pump time clock.

The pump can be turned off manually at any time by pressing the PUMP key. If the heater is running when the pump is turned off, the pump will go into 'COOL DOWN MODE' and continue to run for 5 minutes. If the heater was running within the last 5 minutes, the pump will continue to run for the time remaining to complete a 5 minute cool down. The 'COOL DOWN' mode allows cool water to circulate through the heat exchanger, removing residual heat from the combustion chamber. When the pump is in the 'COOL DOWN' mode, the controller will display the 'COOL DOWN' icon just above the pump icon.

To turn the pump on at any time press the PUMP key. If the heater is in either the 'POOL' or 'SPA' mode, and the water temperature is less than the pool or spa temperature setting the ignition sequence will begin.

7.4.3 Locking/Unlocking the Keypad

Once all of the limits have been set (see Section 7.2, "Setting the LJ Controller Functions and Limits") you may choose to lock the keypad to prevent accidental changing of the limits set. Use the following procedure to lock and unlock the keypad.

1. Press the MODE key repeatedly until the icon °F/°C appears at the top of the display screen.



2. Press the ENTER key. The temperature scale indicator in the lower right corner of the display will start to flash.



3. Press the MODE key one more time. The icon 'ULC' (unlocked) or 'LC' (locked) will flash on the display where the real time clock usually appears.



4. Press the UP or DOWN key to toggle between 'ULC' or 'LC'.



5. Press the ENTER key to accept the choice and return the controller to the NORMAL mode.



Note: Once the keypad is locked, any attempted changes to the limits or functions of the LJ controller will cause the LCD to temporarily display an "Invalid Command" message.

7.5. Remote Control Operation

To connect a remote control system, the LJ controller must first be set up to recognize the remote mode. The set up consists of setting the 'PROGRAM' (pump time clock) 'ON' and 'OFF' times to run for 24 hours,

To set the LJ controller for remote control use, set the 'ON' time for the 'PUMP TIME CLOCK' to 12:00 AM and the 'OFF' time to 11:59 PM. Refer to Section 7.2.5, "Setting the Pump Time Clock". When the pump time clock is set with these limits, it allows the internal time clock of the LJ controller to run the pump for 24 hours. This setup allows the heater to be controlled by the remote input through the Fireman's Switch connection.

An interrupt (on/off) type remote switch can be connected to the heater. To connect a remote ON/OFF type switch to the heater, remove the wire nut from the two red leads of the wire harness that connects to the Fireman's Switch connection on the power circuit board (see Figure 18). Connect the wires from the switch to the leads on the wire harness. This type of remote control will turn the heater on or off, but will not switch between pool and spa settings or allow for temperature adjustments. These functions are still controlled at the LJ controller on the heater.

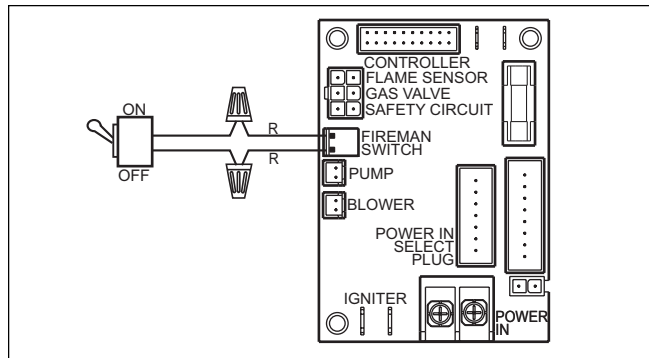



Figure 18. ON/OFF Type remote switch.

The LJ heater also accommodates the use of a more functional remote control. Remote controls that provide their own temperature sensor such as the Jandy Aqualink RS remote control systems can be wired to the Fireman Switch connection. The LJ controller must first be set up to recognize the remote mode. The set up consists of setting the 'PROGRAM' (pump time clock) 'ON' and 'OFF' times to run for 24 hours, setting the controller function to 'SPA' and setting the spa temperature to 104°F (40°C)

To set the LJ controller for remote control use, follow the instructions at the beginning of this section to set the pump to run for 24 hours.

To operate the heater by the remote unit, use the SELECT key  on the LJ controller keyboard to set the heater to the 'SPA' mode.

Then follow the instructions in Section 7.2.3, "Setting the Pool and Spa Temperatures", to set the spa temperature limit to 104°F (40°C). This will allow the remote system's temperature settings to control the water temperature to a maximum of 104°F (40°C).

The LJ controller now acts as a "slave" controller and heater functions are controlled by the remote control system.

To restore control of the heater functions to the LJ controller, disconnect the remote system from the Fireman's Switch, reprogram the pump time clock to desired settings and reset the 'SPA' temperature to the desired setting.

7.6 Adjusting the Pressure Switch

Caution

The pressure switch should be adjusted to turn the heater off when the pump is off. Setting the switch to close at too low of a flow can damage the appliance. Adjust the switch to turn the heater off, not on.

The pressure switch is preset at the factory for activation at 2 psi (14 kPa). Adjust the pressure switch only if any part of the filter system piping is 3 feet (0.91 m) or more above the top of the heater jacket.

Do not adjust the pressure switch if the heater is installed more than 15 feet (4.57 m) below or 6 feet (1.83 m) above the pool surface. Consult your local Jandy representative for recommendations.

On some installations, the piping from the heater to the pool is very short. The back pressure could be too low to trigger the pressure switch. If this happens, it may be necessary to install a directional fitting or elbows where the return line enters the pool. This will increase back pressure enough for the heater to operate properly.

Make sure the pool filter is clean before making any pressure switch adjustment: A dirty filter will restrict the water flow and the pressure switch cannot be adjusted properly. To adjust the pressure switch:

1. Turn the pump 'OFF' by pressing the PUMP key so that the display shows that the pump is 'OFF'. If the heater was running it should go off immediately and the pump will run in the 'COOL DOWN' mode for 5 minutes. If the heater has been running within the last 5 minutes, the pump will continue to run for the remainder of the 5 minute cool down period (see Figure 19).

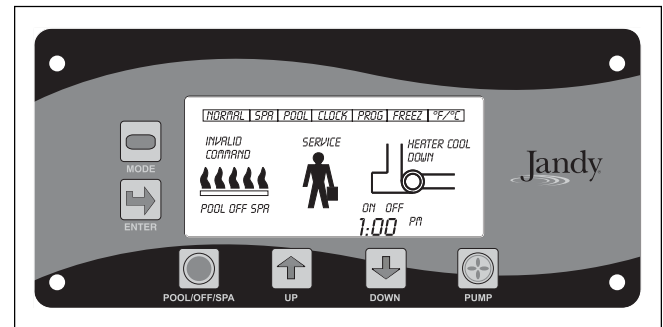

Figure 19. LJ controller display.

2. Set the pool temperature control to the maximum setting. Repeatedly depress the MODE key until the indicator at the top of the display shows 'POOL SET'. Press the ENTER key. Then use the UP key to set the temperature to 104°F (40°C). Press the ENTER key again.
3. Turn filter pump on by depressing the PUMP key. If a two-speed pump is used, make sure it is at high speed.
NOTE: Heater should not be allowed to fire on low speed.
4. Set the controller to 'POOL' by repeatedly depressing the SELECTION key until the display shows that the heater is set to 'POOL'. The heater should start.
5. Pry out the rubber dust plug on the top of the pressure switch.
6. Use a 7/32 inch (5.55 mm) Allen wrench to turn the adjustment screw very slowly clockwise until the heater goes off (see Figure 20).

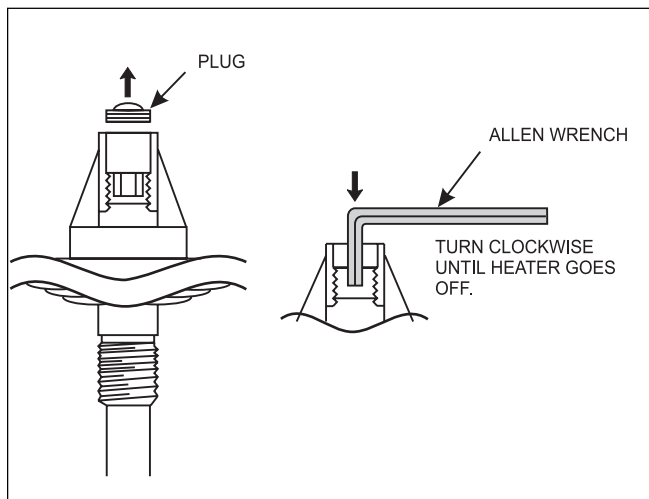

Figure 20. Pressure Switch Adjustment.

7. Slowly turn the pressure switch adjustment screw **counterclockwise** one-quarter turn. The heater should come back on.
8. Check the adjustment. Press the SELECT key to turn the heater 'OFF'. Turn off the power to the heater at the breaker. Unplug the pump relay from the power circuit board. Restore power to the heater. Press the SELECT key to set the heater to 'POOL'. **The heater must not come on.** If the heater does start the firing sequence, immediately press the SELECT key to turn the heater off, disconnect power to the heater, plug the pump relay into the power circuit board and restore the power to the heater. Then repeat Steps 6 and 7. Check the adjustment again. When the adjustment has been checked and verified, press the SELECT key to turn the heater off, disconnect power to the heater, plug the pump relay into the power circuit board and restore the power to the heater.
9. Return the pool temperature control to the desired temperature. Repeatedly depress the MODE key until the indicator at the top of the display shows 'POOL SET'. Press the ENTER key. Then use the UP and DOWN keys to set the heater to the desired temperature. Press the ENTER key again.

7.7. Temperature Rise

A temperature rise test confirms proper water flow through the heater. The temperature rise is the difference between the temperature of the pool or spa water before and after heating, as measured in the header. Perform the following temperature rise test when the installation is complete:

1. Make sure the pool filter is clean.
2. Set the controller to 'OFF' by repeatedly depressing the SELECTION key until the display shows that the heater is 'OFF'.

3. If the filter pump is on, turn it off by pressing the PUMP key and allow up to five minutes for the pump to shut down.
4. Turn off the power supply to the heater at the circuit breaker panel.
5. Remove the drain plug located on the inlet/outlet header of the heater and replace it with a Pete's plug (see Figure 14).
6. Insert a pocket thermometer (see Figure 14) through the Pete's plug into the header.
7. Turn the circuit breaker on to supply the heater with power.
8. Turn the filter pump on and wait 3 minutes. The heater remains off. This allows water from the pool to reach the heater.
9. Record the temperature indicated by the thermometer (cold water).
10. Set the pool temperature control to the maximum setting. Repeatedly depress the MODE key until the indicator at the top of the display shows 'POOL SET'. Press the ENTER key. Then use the UP key to set the temperature to 104°F (40°C). Press the ENTER key again.
11. Set the controller to 'POOL' by repeatedly depressing the SELECTION key until the display shows that the heater is set to 'POOL'. The heater should start.
12. Allow the heater to run for about 3 minutes. Record the new temperature reading (heated water).
13. Subtract the first temperature reading (cold water) from the second temperature reading (heated water). The difference between the two readings is the **temperature rise**. The temperature rise should be within the range shown in Table 7.

Table 7. Temperature Rise and Minimum Flow Rates

Size	Minimum		Minimum		Maximum	
	GPM	(LPM)	°F	(°C)	°F	(°C)
125	20	(76)	27	(15)	36	(20)
175	20	(76)	33	(19)	42	(24)
250	25	(95)	33	(19)	42	(24)
325	30	(114)	28	(16)	38	(21)
400	30	(114)	30	(17)	39	(22)

14. If the temperature rise is below the minimum range indicated, two possibilities arise:
 - a. The supply gas volume is too low.

- b. The system's water flow exceeds 125 GPM (475 LPM), and requires a manual bypass valve for proper operation. Install a manual bypass valve for proper operation. Install a manual bypass valve (see Figure 6 on page 10) and proceed to Section 7.8
15. If the temperature rise is above the maximum, there is not enough water flowing through the heater. Check for clogging in the water filter or restriction in the water pipes.

⚠ Caution

Operation with the temperature rise above maximum or below the minimum can damage the heater and may void the warranty.

16. If the temperature rise is within the correct range, complete the procedure as follows:
- Set the controller to 'OFF' by repeatedly depressing the SELECTION key until the display shows that the heater is 'OFF'.
 - Turn the filter pump off by pressing the PUMP key and allow up to five minutes for the pump to shut down.
 - Turn off the power to the filter at the circuit breaker.
 - Remove thermometer and Pete's plug.
 - Replace the drain plug.
 - Turn on the power to the filter at the circuit breaker.
 - Return the pool temperature control to the desired temperature. Repeatedly depress the MODE key until the indicator at the top of the display shows 'POOL SET'. Press the ENTER key. Then use the UP and DOWN keys to set the heater to the desired temperature. Press the ENTER key again.
6. Turn the circuit breaker on to supply the heater with power.
7. Close manual bypass valve.
8. Set the controller to 'OFF' by repeatedly depressing the SELECTION key until the display shows that the heater is 'OFF'.
9. Repeat steps 8 through 13 of the temperature rise test (see Section 7.7).
10. If the temperature rise is below the minimum stated in Table 6, open the manual bypass valve until temperature rise climbs between the min. and max. range for your size heater. If the minimum temperature rise stated in Table 6 cannot be reached with the manual bypass fully open, then the gas supply volume is too low.
11. If the temperature rise is above the maximum, there is not enough water flowing through the heater. Check for clogging in the water filter or restriction in the water pipes.
12. Once the temperature is within the correct range, safety wire the handle of the manual bypass valve in place and tag the valve to prevent change in the water flow.
13. Complete the procedure as follows:
- Set the controller to 'OFF' by repeatedly depressing the SELECTION key until the display shows that the heater is 'OFF'.
 - Turn the filter pump off by pressing the PUMP key and allow up to five minutes for the pump to shut down.
 - Turn off the power to the heater at the circuit breaker.
 - Remove thermometer and Pete's plug.
 - Replace the drain plug.
 - Turn on the power to the heater at the circuit breaker.
 - Return the pool temperature control to the desired temperature. Repeatedly depress the MODE key until the indicator at the top of the display shows 'POOL SET'. Press the ENTER key. Then use the UP and DOWN keys to set the heater to the desired temperature. Press the ENTER key again.

7.8. Adjusting the Manual Bypass Valve

After the manual bypass valve is installed, use the following procedures to adjust the bypass valve:

- Make sure the pool filter is clean.
- If the filter pump is on, turn it off by pressing the PUMP key and allow up to five minutes for the pump to shut down.
- Turn off the power supply to the heater at the circuit breaker panel.
- Remove the drain plug located on the inlet/outlet header of the heater and replace it with a Pete's plug (see Figure 14).
- Insert a pocket thermometer (see Figure 14) through the Pete's plug into the header.

SECTION 8.

Maintenance

8.1 Water Chemistry

Proper chemical balances are necessary for sanitary bathing conditions as well as ensuring your heater's long life. Be sure to keep your chemical levels within the values indicated in Table 8.

Table 8. Mineral Concentration Levels

Test	Recommended Level
Free chlorine	1.0 to 3.0 ppm
Bromine	3.0 to 5.0 ppm
pH	7.2 to 7.8
Total alkalinity (TA)	80 to 120 ppm
Calcium hardness (CH)	200 to 400 ppm
Langelier saturation index (LSI)	-0.5 to +0.5
Total dissolved solids (TDS)	Less than 2000 ppm
Cyanuric acid	30 to 150 ppm
Copper	0 ppm

Water Pik Technologies, Inc. does not warrant heat exchangers damaged by corrosive chemical levels or excess dissolved solids in pool or spa water.

For spas, it is also necessary to perform water changes in addition to chemical treatment. It is recommended to change the spa water every 60 days for light usage and every 30 days if usage is heavy.

8.2 Seasonal Care

Caution

Do not operate this heater outdoors at temperatures below 20 degrees Fahrenheit (°F) (-7 degrees Celsius [°C]).

8.2.1 Spring and Fall Operation

During periods when the pool is only going to be used occasionally, set the pool and spa control temperatures to 70°F (21°C) (see Section 7.2.3). This prevents the pool from water from becoming chilled, and minimizes the time required to raise the pool water back up to the desired temperature.

In areas subject to only short freeze periods, turn off the heater. The Freeze control function of the heater will start the pump when the water temperature falls to the 'FREEZE SET' temperature (see Section 7.2.4). The pump will run continuously until the water temperature has risen to 2° above the 'FREEZE SET' temperature.

If the heater is not going to be used for a long period of time, shut it down completely. Follow the instructions found on the inside of the heater, or page 23 of this manual.

8.2.2 Winterizing

In areas where freezing temperatures occur in winter, and the pool or spa will not be used, have your service technician perform the following steps:

1. Turn off the main gas supply valve to the heater, outside the heater jacket.
2. Remove heater door.
3. Shut down the heater following the shutdown instructions found on the inside of the heater.
4. Remove the drain plug from the return header (see Figure 21), loosen the drain plug from the inlet/outlet header, and completely drain the heater before the first frost.
5. After all water has drained from the heater, remove the drain plug from the inlet/outlet side. Check for mineral buildup in the openings.
6. Use compressed air to blow out any standing water remaining in the heat exchanger.
7. Grease the threads on the drain plugs and reinstall plugs, but do not tighten.
8. Disconnect the pressure switch from the siphon loop (copper tubing) (see Figure 22).

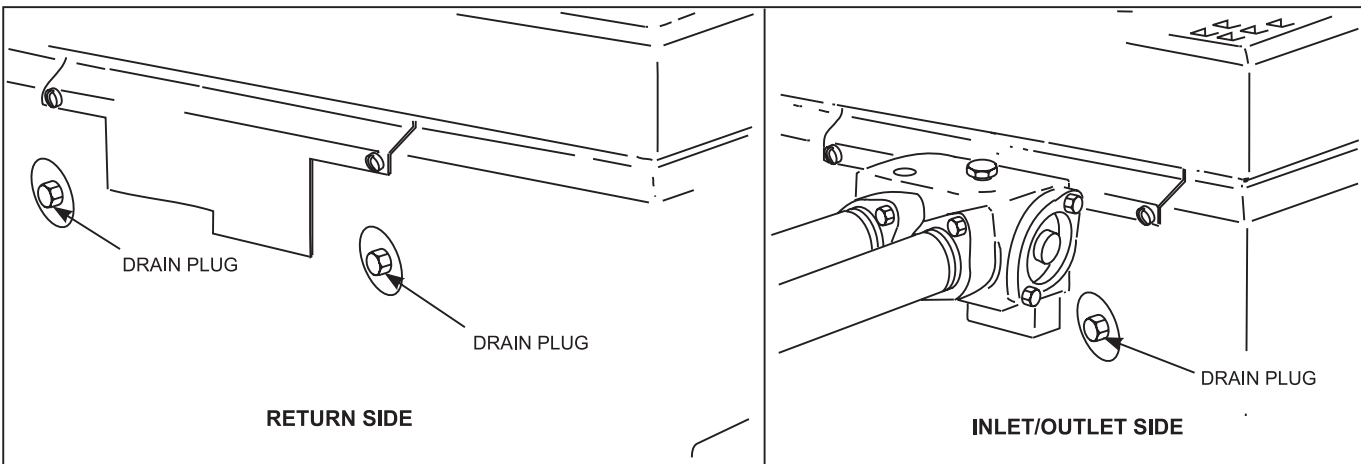

Figure 21. Heater drain locations.

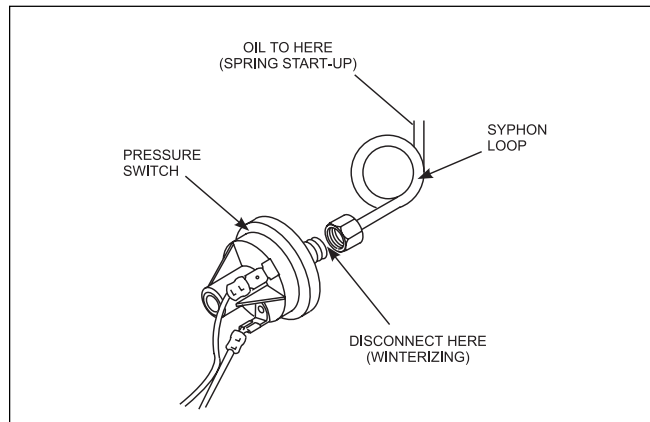

Figure 22. Pressure switch copper tubing.

8.2.3 Spring Start-up

To restart the heater in the Spring, have a professional service technician reassemble the heater as follows:

1. Fill the siphon loop with approximately 5cc of SAE 50, non-detergent oil. Attach the copper tubing to the pressure switch (see Figure 22).
2. Tighten the drain plugs.
3. Make sure that power is supplied to the heater controller and the pump. Turn on the filter pump by pressing the PUMP key and circulate water through the heater for 5 minutes. Check for leaks while circulating.
4. Turn on the main gas supply valve to the heater, outside the heater jacket.
5. Turn on the heater following the lighting instructions found on the inside of the heater, or page 23 of this manual.

8.3 Inspection and Service

Water Pik Technologies designs and constructs the Lite2 heater to provide long performance life when installed and operated properly under normal conditions. Periodic inspections, especially at spring start-up, are important to keep your heater running safely and efficiently through the years. Improper maintenance can result in conditions where nausea or asphyxiation from carbon monoxide or flue gases could cause severe injury, property damage or death.

⚠ WARNING

Improper installation or maintenance can cause nausea or asphyxiation from carbon monoxide in flue gases which could result in severe injury, or death.

8.3.1 Owner Inspection

Water Pik Technologies recommends that you inspect the heater on a continual basis and especially after abnormal weather conditions. The following basic guidelines are suggested for your inspection:

1. Keep the top and surrounding area of the heater clear of all debris.
2. Keep the area around and beneath the heater clean and free of all combustible materials such as paper, leaves, etc.
3. Do not store or use gasoline or other flammable vapors, liquids or chemicals in the vicinity of this or any other appliance.

Ne pas entreposer ni utiliser d'essence ni d'autres vapeurs ou liquides inflammables à proximité de cet appareil ou de tout autre appareil.

4. Do not use the heater if any part has been under water. Immediately call a qualified professional technician to inspect the heater and replace any part of the control system which has been submerged.

N'utilisez pas cet appareil s'il a été plongé dans l'eau, même partiellement. Faites inspecter l'appareil par un technicien qualifié et remplacez toute partie du système de contrôle et toute commande qui ont été plongés dans l'eau.

5. If the heater is equipped with a pressure relief valve, check for corrosion in and around the valve. Twice a year, with the filter pump on, lift the release lever on the top of the valve to make sure that water runs freely through it. If corrosion is found, replace the pressure relief valve. When replacing the valve, be sure that the pump is off. Install the valve so that the discharge is directed away from any area that may be damaged by water.
5. Be sure all combustion air and ventilation openings are not blocked. Check for spider webs and other debris inside the heater, in the vents on all sides of the heater jacket and in the exhaust outlet—especially after a long period of nonuse.

8.3.2. Professional Inspection

Inspections performed at least once a year by a qualified technician are required to maintain your heaters safe and efficient operation. The following basic safety checks must be performed.

1. Check for loose or broken wires and terminal connections.
2. Verify pressure switch operation. Press the SELECT key to turn the heater 'OFF'. Turn off

the power to the heater at the breaker. Unplug the pump relay from the power circuit board. Restore power to the heater. Press the SELECT key to set the heater to 'POOL'. **The heater must not come on.** If the heater does start the firing sequence, immediately press the SELECT key to turn the heater off, disconnect power to the heater, plug the pump relay into the power circuit board and restore the power to the heater. Refer to Section 7.6 "Adjusting the Pressure Switch" for procedures on adjusting the pressure switch. When the adjustment has been checked and verified, press the SELECT key to turn the heater off, disconnect power to the heater, plug the pump relay into the power circuit board and restore the power to the heater.

3. Return the pool temperature control to the desired temperature. Repeatedly depress the MODE key until the indicator at the top of the display shows 'POOL SET'. Then use the UP and DOWN keys to set the heater to the desired temperature.
4. Inspect the electrical controls, specifically the following:
 - a. High limit controls.
 - b. Pressure switch.
 - c. Temperature/Ignition control.
 - d. Automatic gas valve.
5. Inspect the venting system for blockage, leakage, and corrosion.
6. Check for spider webs in or other obstructions in the main burner orifices – especially at Spring start-up. Clean with wire brush if necessary.
7. Conduct a normal operating cycle and observe that the sequence proceeds as intended.

Caution

For your safety, when starting the heater, keep your head and face away from the lower firebox opening to prevent any risk of personal injury.

8. Inspect the external surfaces of the heat exchanger tubes for black carbon soot buildup by placing a mirror between and under the burners when the heater is firing. Remove any soot that has collected on the tubes, and correct the cause.

NOTE: After installation and first start-up, check the heat exchanger for black carbon soot buildup after the following periods of operation: 24 hours, 7 days, 30 days, 90 days, and once every 6 months thereafter.

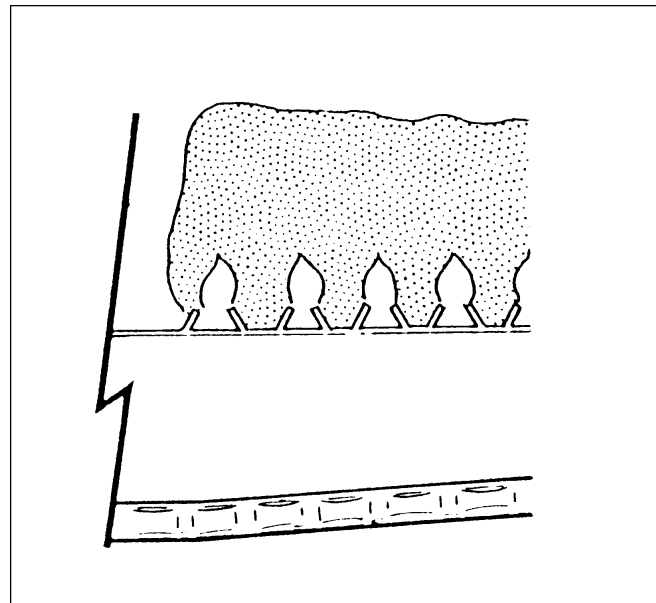

Figure 23. Main Burner Flame.

Proper flames appear:

- a. Blue in color.
 - b. 1 to 4 inches (25 to 102mm) high above burner surface.
9. Perform a temperature rise test in accordance with Section 7.6.
 10. If the heater is equipped with a pressure relief valve, check for corrosion in and around the valve. With the filter pump on, lift the release lever on the top of the valve to make sure that water runs freely through it. If corrosion is found, replace the pressure relief valve. When replacing the valve, be sure that the pump is off. Install the valve so that the discharge is directed away from any area that may be damaged by water.

NOTE: Keep this manual in a safe place for future reference by you and your professional technician when inspecting and servicing the heater.

SECTION 9.

Troubleshooting

9.1 General Heater Troubleshooting

The following table lists some of the more common problems, causes and solutions encountered when running the heater. Most problems occur when the heater is being started for the first time after installation or at Spring start-up. Careful installation and maintenance will help insure years of trouble free use from your Lite2 pool heater.

Troubleshooting Guide

#	Symptom	Cause	Remedy
1.	Pump not operating clock.	A. No power B. Pump defective C. Incorrectly wired	A. Check circuit breakers and power source. B. Replace. C. Recheck wiring including relay if using LJ controller internal
		D. Pump Relay Defective E. Current time not within time clock settings F. Controller defective	D. Replace Pump Relay E. Set time clock and current time F. Replace controller.
2.	Flame roll-out on start-up	A. Blocked flue B. Igniter out of position (delayed ignition) C. Blocked heat exchanger D. Refractory blanket out of place E. Altered draft hood F. Downdraft conditions	A. Remove blockage. B. Correct igniter position. C. Clean and correct as necessary. D. Correct or replace blanket as necessary. E. Install factory-provided draft hood. F. Install draft hood
3.	Spillage at draft hood	A. Cold chimney B. Vent pipe pitches down to chimney C. Blocked chimney D. Draft hood altered E. Prefabricated chimney with incorrect cap	A. Allow heater to operate 5 minutes to create draft action. B. Reinstall vent pipe to pitch up from heater to chimney. C. Remove blockage. D. Install factory-provided draft hood. E. Install U.L. listed vent cap.
4.	Flame has lazy yellow tip	A. Low primary air	A. Correct manifold pressure according to rating plate. Correct orifice size if necessary (see parts list). Clean burner ports if dirty.
5.	Not enough heat	A. Inadequate gas supply B. Low manifold gas pressure C. Heater size inadequate	A. Gas meter too small. Gas line from meter to heater too small. B. Gas pressure on heater manifold, should be adjusted to 4.0"W.C. for natural gas, 9.0"W.C. for propane. C. Replace with heater of higher input.
6.	Heater pounding or knocking.	A. Water flow through heater too low	A. Check temperature rise between inlet and outlet heater piping. See section 7.6 for recommended range of temperature rise. If temperature rise is above the maximum recommended, increase pipe size or pump capacity or locate obstruction. Check for closed valve in system
7.	Heater condensing	A. Low water temperature	A. Flue product moisture will condense at the start-up until the heater water temperature reaches the normal operating conditions.
		B. Heater Plumbed backwards	B. Correct Plumbing
8.	Igniter lights but main burners will not come on	A. Gas valve not at "on" position B. Air in gas line C. Gas valve failed	A. Turn knob to "on" position. B. Cycle ignition sequence until air is out of the gas line. C. Replace gas valve.

9.2 LJ Controller Service Codes

9.2.1 Explanation of Service Codes

The LJ controller monitors several functions of the heater. In the event of a malfunction, the controller will display an service code where the inlet temperature is usually displayed and a service icon in the middle of the display. See Figure 24 for appearance and location of typical service code display.

The service codes are listed on the following pages.

Only two of these service codes are reconcilable without the services of a qualified technician. The first is the case where the heater does not start after the first three attempts, FL2. This may occur after a prolonged period of nonuse of the heater, especially at spring start-up. However, the repeated appearance of this error requires the service of a qualified technician.

The other case is that of a temporary brown-out condition, FL5. If the brown-out is regional, then the controller will automatically reset the heater when full

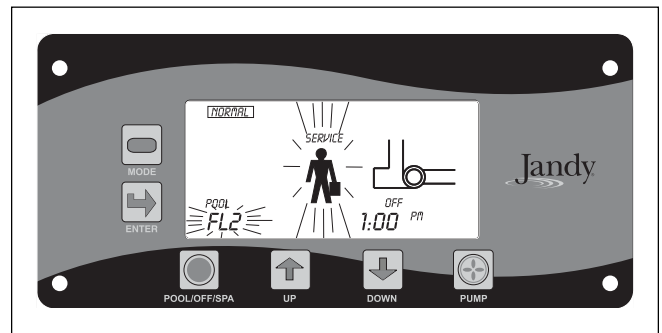

Figure 24. Typical Service Code Display

power is restored by the electric company. However, if the brown-out is due to a low voltage supply problem only on the heater circuit, then immediately shut off the electrical supply to the heater and call a certified electrician.

To clear the FL2 service code, turn off the heater by using the SELECT key to turn the heater to the 'OFF' position and then turn it back to either 'POOL' or 'SPA'. The heater will now go back to the

normal operating mode. If there is a call for heat the heater will attempt ignition again. If the ignition fails again, contact a qualified technician to check the heater.

All other service codes will need the attention of a qualified technician to resolve the problem.

9.2.2 Resetting LJ Controller Service Codes

The LJ controller will display service codes to help in identifying fault conditions that effect the operation of the heater (see Section 9.2.1).

There are three service codes that will reset automatically once the fault condition has been resolved.

Service code FL1, "temperature sensor shorted", will reset after the short has been repaired, or a new sensor installed. The display will show the normal operating icons.

Service code FL3, "flame detected when no flame should exist", will reset after the problem has been resolved.

Service code FL5, "brown-out condition exists", will also reset after the condition has been resolved. However, the reset may take up to 3 minutes. The LJ

controller checks the power supply voltage every 3 minutes. If the supply voltage drops below 85% of the nominal supply voltage, the display will show the FL5 service code and the heater will not start the ignition sequence. The controller will check the supply voltage again 3 minutes later. If the low voltage condition still exists the FL5 service code will remain. If the actual supply voltage is above 85% of the nominal supply voltage, the service code will clear automatically from the display and the heater will resume normal operation. If the heater was in either 'POOL' or 'SPA' mode when the brown-out condition was detected, it will remain in that mode when the condition is resolved. If the water temperature is less than the thermostat setting, the ignition sequence will start automatically and the heater will operate normally.

Once any other service code has been displayed, it will need to be reset after the fault condition has been resolved. Once the problem has been identified and repaired, press the SELECT key  repeatedly until the display shows the 'OFF' icon. Then press the SELECT key again to set the controller to either 'POOL' or 'SPA'. The controller should send the heater through the ignition sequence and the heater will operate normally.

LITE2 LJ CONTROLLER HEATER SERVICE DIAGNOSTIC GUIDE

SERVICE CODE	CAUSE	REMEDY
FL 0 <i>(open switch in the safety circuit)</i>	1. Pressure Switch opened A. Pump is not running. B. Low pump/water pressure. C. Air is in the water line. D. Pressure switch fault.	A. Turn pump on or check to see that external time clock is synchronized with LJ controller time clock. B. Clean filter or clear blockage/check position of valves in plumbing system. C. Check for air leaks in plumbing system. D. Adjust or replace pressure switch. Refer to qualified personnel.
	2. Hi Limit Switch tripped A. Water temperature in heater exceeds the internal limit. B. Limit switch fault.	A. Identify and correct cause of overheating. Refer to qualified personnel. B. Identify and correct loose connections or replace switches. Refer to qualified personnel.
	3. Fusible Link opened A. Internal cabinet temperatures exceed the fusible link limit. B. Fusible Link fault.	A. Identify and correct cause of overheating. Refer to qualified personnel. B. Identify and correct loose connections or replace fusible link. Refer to qualified personnel.
FL 1 <i>(temperature sensor)</i>	1. Temperature Sensor error A. Temperature sensor opened or shorted. B. Failed sensor.	A. Check for loose connections and inspect sensor wires and routing. B. Replace temperature sensor. Refer to qualified personnel.

SERVICE CODE	CAUSE	REMEDY
FL 2 <i>(failed ignition)</i>	1. No Ignition	
	A. Low gas supply pressure.	A. Identify and repair incorrect supply pipe size or pipeline blockage. Refer to qualified personnel.
	B. Air in gas line.	B. Shutdown heater and restart. If the heater does not ignite, refer to qualified personnel.
	C. No gas flowing	C. Be sure that the manual gas cock and the automatic valve are in the "ON" position. Check for loose wire connections at gas valve.
	D. Gas Valve fault.	D. Replace gas valve. Refer to qualified personnel.
	2. Ignition, but no Flame Sensing Capabilities	
	A. Flame sensor is not in the flame.	A. Ensure that the flame sensor is aligned over the burner. Refer to qualified personnel.
	B. Flame sensor circuit is open.	B. Identify and correct loose connections. Refer to qualified personnel.
	C. Flame sensor rod is grounded.	C. Ensure that flame sensor is installed properly and is not in contact with burner or heater jacket. Refer to qualified personnel.
	D. Flame sensor circuit is shorted.	D. Inspect flame sensor rod, wiring and connections between sensor and power circuit board. Refer to qualified personnel.
	E. Flame sensor circuitry is not well grounded.	E. Ensure that the green wire from the 6-pin connector the power circuit board is tightly attached to the ground screw with a star washer.
	F. Low gas supply pressure.	F. Identify and repair incorrect supply pipe size or pipeline blockage. Refer to qualified personnel.
	G. Heater is wired incorrectly	G. Ensure proper wiring. See wiring diagram in manual or on door of heater for details. Refer to qualified personnel.
H. Failed Sensor.	H. Replace flame sensor.	
3. Rapidly Cycling Pressure Switch		
A. Air leak in water line or pump.	A. Locate and repair leak.	
B. Insufficient back-pressure to heater.	B. Install restrictive fitting at pool/spa outlet. Refer to qualified personnel.	
FL 3 <i>(flame detected when no flame should exist)</i>	1. Flame Sensor Error	
	A. Flame exists prior to ignition sequence.	A. Carefully inspect heater for signs of fire damage. Refer to qualified personnel.
	B. Failed controller.	A. Replace controller. Refer to qualified personnel.
FL 4 <i>(igniter)</i>	1. Igniter Failure	
	A. Igniter circuit is open	A. Check fuses on igniter wires. Identify and correct loose connections or broken wires. Refer to qualified personnel.
	B. Element has a fine crack in it.	B. Measure room temperature resistance and ensure value is in the correct range. See manual for details. Refer to qualified personnel.
	C. Igniter fault.	C. Replace igniter. Refer to qualified personnel.

SERVICE CODE	CAUSE	REMEDY
FL 5 (brown-out)	1. Brown-out Condition A. Incoming voltage is too low to safely operate heater. B. Heater supply voltage is 115V but power conversion plug is plugged in on 230V side.	A. No Service Required. Heater will automatically reset itself once proper voltage is restored. If error persists, Refer to qualified personnel. B. Reverse power conversion plug.
FL 6 (24V signal to gas valve)	1. Power Module Failure A. 24V signal is not being sent to energize the gas valve.	A. Replace power module board. Refer to qualified personnel.
FL 7 (remote operation circuit)	1. Remote Operation Circuit A. Remote control switch circuit is open. (Controller is not in remote control mode) B. Remote control switch circuit is not open.	A. Identify and correct loose connections. Refer to qualified personnel. B. Replace power module board. Refer to qualified personnel.

SECTION 10. Professional Maintenance and Service

WARNING

SERVICING SAFETY

Some of the servicing procedures for the Lite2 model LJ pool heater are hazardous because they involve fuel gas, electricity, moving parts and procedures which require testing or temporary bypass of safety controls. For this reason, the heater must be serviced only by a qualified professional service technician.

IMPROPER SERVICE HAZARD

The Lite2 model LJ pool heater incorporates unique design features. Incorrect service of this heater can result in personal injury or damage to property. To avoid such hazards, the heater must be serviced only by a qualified professional service technician.

10.1.General Information

A qualified professional technician must service the Lite2 model LJ pool heater using Water Pik Technologies service procedures. Before calling for service, however, the owner should check for obvious problems. The other components in the pool system, including pump, filters and strainers, water valves, gas supply, electrical power and time clocks, have an effect on heater operation.

Confirm that the LJ heater control is set to 'POOL' or 'SPA' and that the corresponding temperature limit is set high enough to make the heater operate. Make sure the pump is operating, that the filter

and strainers aren't clogged, that there are no mispositioned water valves, that the gas or electric power supplies aren't shut off and that time clocks are properly adjusted. Also be sure that there is no blockage of the vent or louvers which supply combustion air to the burners.

10.2.Natural-Draft Combustion System

The Lite2 model LJ pool heater has an atmospheric combustion system. This system is illustrated in Figure 25.

As the heated exhaust gases rise out of the combustion chamber, flow is created through the system and fresh combustion air is drawn into the heater through the louvers cut into the front and sides of the heater. Gas is forced through an orifice into the open end of a burner. When the gas flows into the burner, a "negative" pressure is created at the opening of the burner. This negative pressure pulls air into the burner with the gas and mixes the two together. As the gas/air mixture flow through the burner ports it is ignited in the combustion chamber. Hot combustion products then raise through a highly efficient heat exchanger. Combustion products then enter a flue collector and are directed to the outdoors through the grate top of the heater or a vent pipe and cap.

10.3.Heater Components and Their Operation

1. **Gas valve / Regulator** - The gas valve controls gas flow into the manifold. It provides flow only when the temperature controls require heat and only if all safety controls enable operation. It is also a *positive pressure regulator*. It regulates the gas pressure in the manifold to specifications addressed earlier in this manual. This is necessary for proper operation of the burner system.

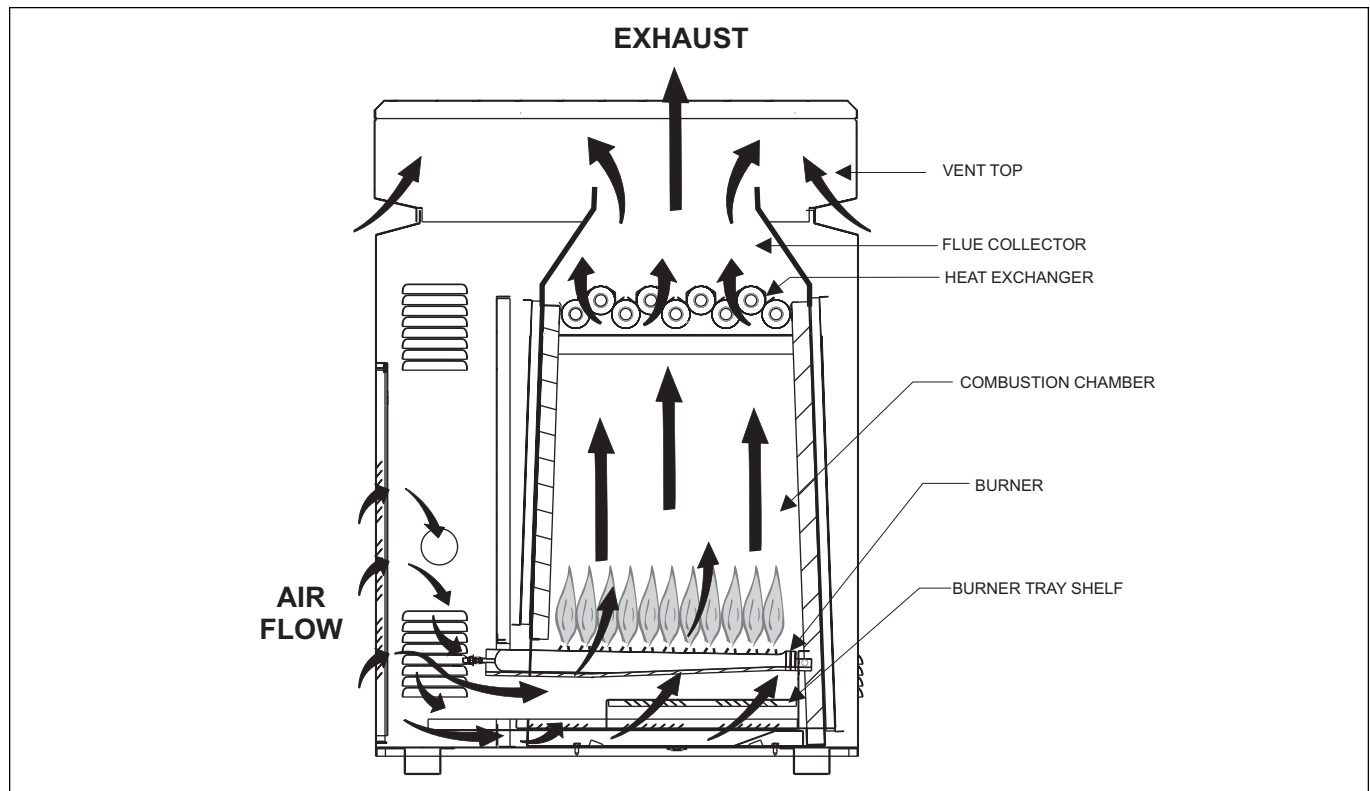

Figure 25. Atmospheric Combustion System

2. **LJ Temperature Control/Ignition Control Combination System-**

a) Temperature Control-The Jandy LJ controller is an electronic control which senses water temperature by means of a thermistor and controls heater operation to bring the water to the temperature selected. It has an option for two separate thermostat settings which are typically used to set pool and spa temperatures. A push-button selector key is used to switch between settings.

b) Ignition Control - The ignition control is integrated with the temperature control. It provides energy for ignition of the air/gas mixture, monitors the flame and controls the gas valve. When the temperature control requires heat, the ignition control provides a pre-purge of the combustion chamber. Then it applies electrical power to a “hot surface” igniter. When the igniter is hot enough, the ignition control opens the gas valve. It has sophisticated means to sense ignition and flame condition so that unburned gas will not escape. After the burner is shut off, the ignition control continues operation to provide a post-purge period.

3. **Igniter -** The hot surface igniter is a ceramic composite element which becomes very hot when electrical power is applied to it. The hot surface igniter directly ignites the air/gas mixture in the combustion chamber.

4. **Flame Sensor -** The flame sensor is the electrode through which the ignition control detects “rectification” of current passed through the flame. Inadequate rectification indicates an unsatisfactory flame condition. The ignition control responds to the flame signal provided by the flame sensor.
5. **Limit Switches -** Two limit switches prevent excessive water temperature - one within the heat exchanger and one for water leaving the heater. If either senses excessive temperature, burner operation is interrupted.
6. **Water Pressure Switch -** This control senses whether or not water is available to the heater by measuring back pressure inside of the heat exchanger. If the pool water pump fails or the water filter is blocked, the pressure switch prevents operation of the burner. It can be affected by the installation
7. **Fusible Link -** This is a single-use switch which detects abnormal temperature in the component vestibule. It is a fusible link which is held to the inner panel just above the burner tray by a sheet metal bracket. Excessive temperature in the component compartment, possibly due to a blocked flue or flame roll-out, will cause the link to fail. This opens the safety circuit which shuts off the gas valve and shuts the heater down.

CIRCUIT TEST POINTS

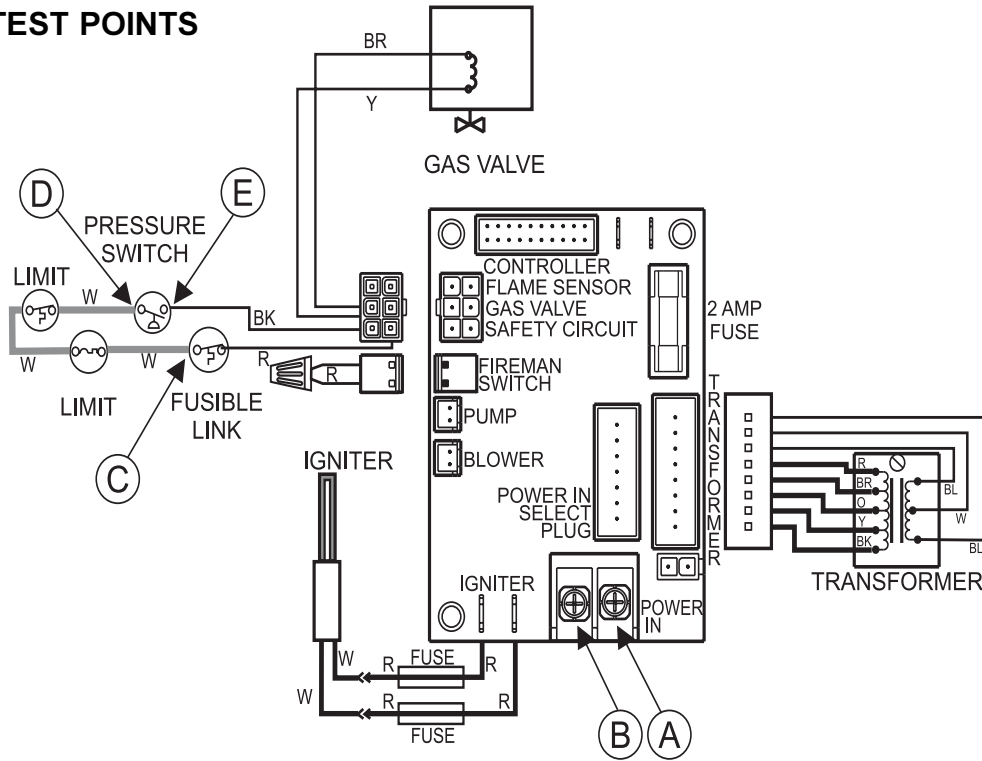

POWER DISTRIBUTION BOARD TEST POINTS

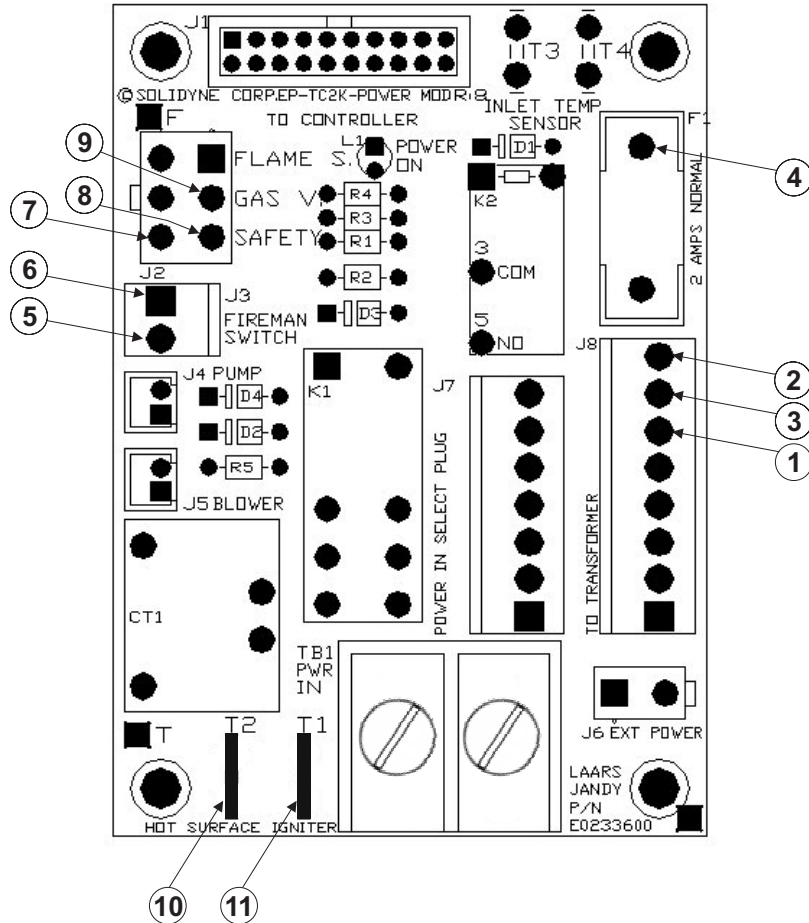

Figure 26. Power and Control Circuit Test Points

10.4. Electrical Troubleshooting

This section describes procedures for checking the electrical power and control components of the heater one at a time and in the order they appear in the control circuit.

Note: Pump must be running during the troubleshooting procedure.

These procedures require a Volt-Ohm meter with a minimum 0-250 VAC voltage range, and 0-1000 Ohm resistance range. Figure 26 shows the power and control circuits, and where to take measurements. Location numbers and letters in circles have been added, and will be referenced in the following sections.

As stated at the beginning of this manual, some of these procedures are hazardous. Only a qualified service technician should service the heater.

10.4.1. Electrical Power Supply

The electrical components of the Lite2 pool heater are designed to operate with supply voltage ranging from 98V to 126V at 60 Hz if connected to a nominal 115 volt power supply or 196V to 253V at 60 Hz if connected to a nominal 230 volt power supply. Measure supply voltage at the “hot” and “neutral” screw terminals in the heater electrical junction box (identified as points A and B on the wiring diagram). If no voltage is present, correct this external power supply problem to the heater. Circuit breakers, time clock settings or similar devices may be the problem. Voltage outside of the above ranges may be due to poor wiring, poor connections, other loads such as air conditioning compressors or to an electric utility company problem. Arrange for correction of the voltage as appropriate.

10.4.2. Controller

The controller must be operational in order to check the control circuits of the heater. If the red LED on the power distribution board is on but the controller does not show a display, then it is defective. Replace the controller. If the LED is not on, then check the control circuits as outlined in the following sections.

10.4.3. Control Circuit Troubleshooting

The heater controls and sensors are powered by three major circuits on a power distribution board (PC board). 115 VAC or 230VAC is brought to the power distribution board by the heater supply voltage. The voltage is then transmitted through the board and the power conversion plug to the igniter and to a transformer. When 115V is supplied to the heater, the power conversion plug passes the signal unchanged to the igniter and configures the input to the transformer for 115V. When 230V is supplied to the heater, the power conversion plug modifies the voltage to 115V before sending it on to the igniter and configures the input to the transformer for 230V. It is important to be

sure that the correct side of the power conversion plug is plugged into the power distribution board. The transformer converts the 115 volt AC or 230 volt AC supply into two separate outputs, 24 volts AC and 12 volts AC. These voltages are supplied back to the power distribution board where the 24 volt signal is used to power the fireman switch, safety circuit and gas valve, while the 12 volt signal is used to power the keypad controller. Troubleshooting is done by probing for voltage at various points on the power distribution board, and heater components to determine which component is preventing operation. Check points are indicated on Figure 26. The recommended procedure steps through each circuit in a sequential way, and each section assumes that components from all previous sections have been tested and are operational. However, verifying voltage at any of the numbered points in that circuit confirms that all prior components of the circuit are operational. Experienced technicians may be able to shorten the process by going directly to one of the intermediate major test points. For example, if 24 volts is measured at test point 8, then all components in the circuit prior to test point 8 (fireman switch and entire safety circuit) are operational.

10.4.3.1. Transformer

To check the 24 volt transformer output, attach the black lead of the voltmeter to the transformer connector where the blue wire enters near the center of the connector (test point 1 on Figure 26). You will need to push the voltmeter lead into the back of the connector along side of the wire pin. Touch the free lead of the meter to the transformer connector where the second blue wire is attached at the end of the connector (test point 2). The meter should show 20-28 volts. If there is no voltage, replace the transformer. To test the 12 volt transformer output, leave the black lead of the meter at test point 1 and touch the free lead of the meter to the transformer connector where the white wire is attached (test point 3). The meter should show 10-14 volts. If there is no voltage, replace the transformer.

10.4.3.2. Fuse

Leaving the black voltmeter lead in place at test point 1, touch the free lead to the end of the fuse (test point 4). The meter should read 20-28 volts. If there is no voltage, the fuse has failed. Inspect the rest of the wiring, especially the safety circuit, to be sure that there is no “short” such as contact of a terminal with the heater chassis or another terminal which may have caused the fuse to fail. Correct any such condition and replace the fuse.

10.4.3.3. Fireman Switch and External Interlocks

Check the voltage going to the external device. Move the black voltmeter lead to test point 2. (This lead can be left in place for most of the testing.) Touch the free lead of the meter to the fireman switch connector where the red wire is attached at the lower end of the connector (test point 5). The meter should read 20-28 volts. If there is no voltage, there may be a bad connection on the power distribution board and the board may need to be replaced. If voltage is detected at test point 5, move the free lead of the meter to the fireman switch connector where the other red wire is attached at the upper end of the connector (test point 6). The meter should read 20-28 volts. If there is no voltage, the time clock switch or other external interlock may be mis-adjusted, mis-connected or defective. Correct this external problem.

10.4.3.4. Fusible Link

Check the voltage going to the safety circuit. Leave the black voltmeter lead in place at test point 2. Touch the free lead of the meter to the safety circuit of the six pin connector where the red wire is attached at the lower left corner of the connector (test point 7). The meter should read 20-28 volts. If there is no voltage, there may be a bad connection on the power distribution board and the board may need to be replaced. If voltage is detected at test point 7, move the free lead of the meter to the terminal of the fusible link where the white wire is connected (test point C).

If no voltage is detected at test point C, the fusible link has failed. This indicates higher than normal temperatures in the component compartment (vestibule). Normal component compartment temperature is well below 300°F. The fusible link is designed to fail at temperatures above 305°F. Excessive temperature might be due to a blocked flue or heat exchanger. Clean the heat exchanger and clear the flue and vent of any restrictions. Sometimes the fusible link fails due to flame roll-out. Flame roll-out may be caused by delayed ignition or downdrafting in windy areas. Thoroughly investigate the causes for flame roll-out and correct the problem when replacing the fusible link.

10.4.3.5. Limit Switches

Since the limit switches are not easily accessible, you can check the voltage going into the component after the limit switches in the circuit. If voltage is detected there, then the limit switches are closed and are operational.

Check the voltage going to the water pressure switch. Leave the black voltmeter lead in place at test point 2. Touch the free lead of the meter to the terminal of the water pressure switch where the white wire is connected (test point D).

If there is no voltage, one of the limit switches is open. This is normally due to excessive water temperature, which should be thoroughly investigated before replacement of limit switches. Excessive water temperature may be caused by low water flow. Water flow deficiency may be due to obvious problems such as a defective pump or blocked water filter. Alternatively, excessive water temperature may be due to over-firing, or to a problem with the water piping or the heater's internal bypass control. Over-firing might be a result of an incorrect gas orifice or supply of propane gas to a heater intended for natural gas. If there are no such fundamental problems, identify which of the switch is open by *temporarily* connecting a jumper wire across its terminals. Replace a defective limit switch. Limit switch access is through the limit switch cover on the side of the heater to which water pipes are connected.

Note that the limit switches have different trip points, and it is important that replacements are correct. The 150°F switch has a red dot on the top of the brass fitting, and must be installed in the lower (horizontal) well in the header. The 135°F switch has no dot and must be installed in the upper (vertical) well in the header.

10.4.3.6. Water Pressure Switch

If voltage is detected at test point D, move the free lead of the meter to the terminal of the water pressure switch where the white wire is connected (test point E).

If there is no voltage, the pressure switch contacts are open. This is almost always due to a water flow deficiency, the most common one being a blocked water filter or defective pump. However, sometimes it is due to blockage of the copper siphon loop tube or mis-adjustment of the switch. Investigate thoroughly, referring to Section 7.9 on "Adjustment of Pressure Switch". If there is no problem with the pool system or pressure switch adjustment, replace the pressure switch.

If test point E shows 24V, move the free lead of the meter to the safety circuit of the six pin connector where the black wire is attached at the lower right corner of the connector (test point 8). If there is no voltage at test point 8, then the connection from the pressure switch to the power distribution board is bad. Replace the six pin connector.

10.4.3.7. Gas Valve Voltage

Check the voltage going to the gas valve. Leave the black voltmeter lead in place at test point 2. Touch the free lead of the meter to the gas valve terminal where the brown wire is attached at the center position of the right side of the connector (test point 9). This test point will have voltage present only during a trial for ignition or during normal operation. The meter

should read 20-28 volts. If there is no voltage, there may be a bad connection on the power distribution board and the board may need to be replaced.

Listen closely to the gas valve when it is first energized (24V first appears at test point 9 during the trial for ignition). There should be an audible "click" when the valve opens.

If there is voltage at test point 9, but the gas valve does not open, replace the valve.

⚠ WARNING

The igniter and some terminals of the power distribution board utilize 115V or 230V power and require appropriate servicing precautions. Note that wires and terminals of these components may be "hot" even when the component is not operating.

10.4.3.8. Igniter/Ignition Control

With the igniter leads connected to the terminals on the power distribution board there will be voltage of 98-126 VAC between test point 10 and test point 11 if the heater is connected to a 115V supply. When the supply is 230V, a regular voltmeter will read only 49-64 VAC because of the way that voltage is reduced by the power distribution board. However, a true reading can be obtained by using an RMS voltmeter if one is available. When using an RMS voltmeter, a reading of 98-126VAC is expected. This voltage will be applied only when there is an attempt to ignite the burner or when the ignition control's flame sensing system has determined that it is OK to allow burner operation. Even if voltage has been confirmed at the end of the safety circuit, the "trial for ignition" sequence is imposed by the ignition control. This sequence consists of a 15 second period of pre-purge, a 10 second period for heat-up of the igniter and a 12 second trial for ignition. During this last 22 seconds there is voltage between test point 11 and test point 12. If satisfactory ignition is not achieved, the igniter is turned off and the system waits for a 45 second post-purge period. The system may go through this cycle as many as three times, but thereafter it is "locked out" by the ignition control. Additional attempts will be made only if the call for heat is interrupted by turning off electrical power or setting the LJ controller to "Off" and then back to "Pool" or "Spa".

To trouble shoot the ignition control, connect the voltmeter leads at test points 10 and 11, and set the LJ controller to call for heat. Observe that the normal ignition sequence takes place. After the 15 second prepurge, note the voltage between test points 10 and 11. Then look for the glow of the igniter by placing a mirror on the bottom of the burner tray. If voltage doesn't appear between points 10 and 11 during the trial for ignition, replace the power distribution board.

If the correct voltage is detected between points

10 and 11 during the trial for ignition but the igniter does not glow, check the connections to the igniter. Disconnect the igniter wires from the in-line fuse harnesses and the fuse harnesses from the power distribution board. Using an ohmmeter, check each fuse and harness for continuity. If the ohmmeter reads an open circuit, the fuse has failed. The fuses are in place to protect the power distribution board in the event of an igniter short circuit. If either of the fuses has failed, replace the igniter before replacing the fuse.

If the fuses are intact, check the igniter with the ohmmeter. Place one lead of the meter on each wire of the igniter. The resistance should read between 25 and 300 Ohms, depending on the temperature of the igniter. If the meter reads outside of this range or shows an open or short circuit, replace the igniter.

**SECTION 11.
Replacement Parts**

11.1 Ordering Information

To order or purchase parts for the Lite2 model LJ pool/spa heater, contact your nearest Jandy dealer or distributor. See the Jandy web site at www.jandy.com for the nearest service center. If they cannot supply you with what you need, contact Customer Service at Water Pik Technologies, P.O. Box 6000, Petaluma, California, 94954, Telephone (707) 776-8200 extension 245.

NOTE: To supply the correct part it is important that you state the model number, serial number and type of gas when applicable. This information is on the rating plate inside the heater.

11.2 Parts List

The following three pages contain a parts list, general exploded view and detailed exploded views to aid in parts identification. Please refer to these pages when ordering parts for your Lite2 pool/spa heater.

Key No	Description	Model No	Order Part No.
MAINGASASSEMBLY			
1	Burner Tray Assy, NAT	125-400	R0383601-05
1	Burner Tray Assy, LPG	125-400	R0383701-05
2	Burner Tray, Shelf Only	125-400	R0317001-05
3	Gas Valve, NAT	All	R0317100
3	Gas Valve, LPG	All	R0319600
4	Gas Orifice, NAT 0 - 3,000 ft alt. (EA.) (Note 1)	All	L0032200
4	Gas Orifice, LPG 0 - 5,000 ft alt. (EA.) (Note 2)	All	L0032900
5	Anti-Rotation Bracket	All	10835900
6	Burner, Main	All	L0052300
7	Burner Manifold	125	L0052200
7	Burner Manifold	175	L0006300
7	Burner Manifold	250	L0006400
7	Burner Manifold	325	L0006500
7	Burner Manifold	400	L0006600

Key No	Description	Model No	Order Part No.
ELECTRICAL SYSTEM			
8	Heater Control Assembly	All	R0366200
9	High Voltage Assembly	All	R0366500
10	Transformer with Wiring Harness	All	R0366700
11	Power Control Board	All	R0366800
12	115/230 VAC Conversion Plug	All	R0366900
13	Bezel	All	S0069800
14	Temperature Sensor	All	R0367000
15	Gasket, Temperature Sensor	All	E0237700
16	Temperature Sensor Retainer Bracket	All	10447300
17	Retainer Bracket Screw	All	F0009100
18	Pressure Switch & Siphon Loop Assembly (2 PSI)	All	R0097600
19	Pressure Switch, 2 PSI	All	R0013200
19	Pressure Switch, 1 PSI	All	R0011300
19	Pressure Switch, 1-10 PSI	All	R0015500
20	Siphon Loop Assembly	All	R0057800
21	High-Limit Switch Assembly	All	R0023200
22	High-Limit Switch, 135° F	All	R0022700
23	High-Limit Switch, 150° F	All	R0023000
24	High-Limit Switch Retainer Boot (not shown)	All	S0098900
25	High-Limit Switch Wire Harness	All	10419301
26	High-Limit Switch Retainer Clip	All	10418400
27	High-Limit Switch Cover	All	10418300
28	Fusible Link Assembly	All	R0012200
29	Fusible Link Bracket	All	10479900
30	Igniter Box Assembly Kit	All	R0383900
31	Igniter	All	R0367100
32	Igniter Fuse Assy (set of 2)	All	R0383300
33	Flame Sense Rod	All	R0367200
34	Wire Harnesses, Temp/Ignition Control (not shown)	All	R0366600
VENTSYSTEM			
35	Top Enclosure	125-400	R0343401-05
36	Top Filler Plate	125-400	R0343701-05
37	Rainshield Kit	125-400	R0318301-05
38	Flue Collector Assembly	125-400	R0316401-05
39	Outdoor Vent Cap (U.S.)	125-400	10561501-05
39	Outdoor Vent Cap (Canada only)	125-400	10561511-15
40	Indoor Drafthood (U.S.)	125-400	10561401-05
40	Indoor Drafthood (Canada only)	125-400	10561411-15
41	Flue Transition Plate	125-400	10861901-05
42	Adapter Plate	125-400	10535301-05
43	Clip	All	10211000
44	Flue Collector Hold Down Clamp	All	10726000
WATERSYSTEM			
45	Inlet/Outlet Header, 2"	All	R0056400
45	Inlet/Outlet Header, Bronze, 2"	All	R0016800
46	Return Header (Includes set of 9 gaskets)	All	R0058300
46	Return Header, Bronze (Includes set of 9 gaskets)	All	R0054600
47	Header Bolt Assembly (Set of 8)	All	R0057000
48	Bolt for Headers, 2 1/2"	All	F0046100
49	Washer for Headers	All	F0011100
50	Nut for Headers	All	F0003100
51	Header Gasket Assembly (Set of 18)	All	R0050800
52	Flange & Gasket Assembly (Set of 2)	All	R0055000
53	Flange, 2"	All	10573500
54	Flange Gasket, 2"	All	S0078000
54	Flange Gasket, 1 1/2 - 2"	All	S0078100
55	Flange Sleeve, 2"	All	S0078200
56	Flange Bolt	All	F0031700
57	Rubber Grommet for Drain Plug	All	R0316300
58	Grommet, Sealing, 2" (Not Shown)	All	S0116200
59	Brass Connector Body	All	P0019701
60	Brass Drain Plug 1/4"	All	P0026800
61	Brass Plug, 3/4"	All	P0027000
62	By-Pass Assembly w/o spring (Iron Cap)	All	R0013100
62	By-Pass Assembly with spring (Bronze Cap)	125-400	10701401-05
63	By-Pass Valve Rod	All	S0079800
64	Brass Nut (For Rod)	All	F0048400
65	By-Pass Valve Disc	All	R0011500
66	By-Pass Valve Control Cap (Iron)	All	10452200
66	By-Pass Valve Control Cap (Bronze)	All	10557400
67	Control Cap Bolts (2 Required)	All	F0041600

Key No	Description	Model No	Order Part No.
WATERSYSTEM (Continued)			
68	By-Pass Valve Spring, Purple	125	S0079900
68	By-Pass Valve Spring, White	175	S0061400
68	By-Pass Valve Spring, Red	250	S0061300
68	By-Pass Valve Spring, Blue	325	S0061200
68	By-Pass Valve Spring, Black	400	S0070100
69	By-Pass Valve Gasket	All	R0011400
70	Heat Exch. Tube Assy. (Incl. set of 18 gaskets)	125-400	R0018101-05
71	Heat Exchanger Baffle (8 Required)	125-400	10697401-05
72	Baffle Retainer	All	S0083900
73	Heat Exchanger Support Clip (2 Required)	All	10457000
74	Flow Restrictors (2 Required) (Not Shown)	125	S0000300
75	Heat Exchanger End Baffles (2 Required)	125-400	R0332301-05
FIREBOX COMPONENTS			
76	Complete Combustion Chamber Assy.	125-400	R0383101-05
JACKET COMPONENTS			
77	Door with Latch	125-400	R0343601-05
78	Jacket Assembly, Less Top Assembly	125-400	R0343501-05
79	Gap Closure, Inlet/Outlet	All	R0344300
80	Gap Closure, Return	All	R0344400
81	Button Plug, 1-3/4"	All	F0035300
82	Button Plug, 7/8"	All	F0032300
83	Button Plug, 2" (With hole for gas line)	All	F0056600
OPTIONAL COMPONENTS			
84	Non Combustible Base	125-400	10521701-05
85	Pressure Relief Valve 3/4" NPT, 75 PSI	All	R0040400
86	Touch Up Spray Paint, Pewter	All	X0022700
87	Touch Up Spray Paint, Black	All	X0022900

Notes:

1. For altitudes 2,000 Ft above sea level, call factory for orifice size.
2. For altitudes 5,000 Ft above sea level, call factory for orifice size.
3. Gaskets and hardware are included in all kits that require the removal of a gasket as part of the procedure to replace a part.

11.3 General Exploded View

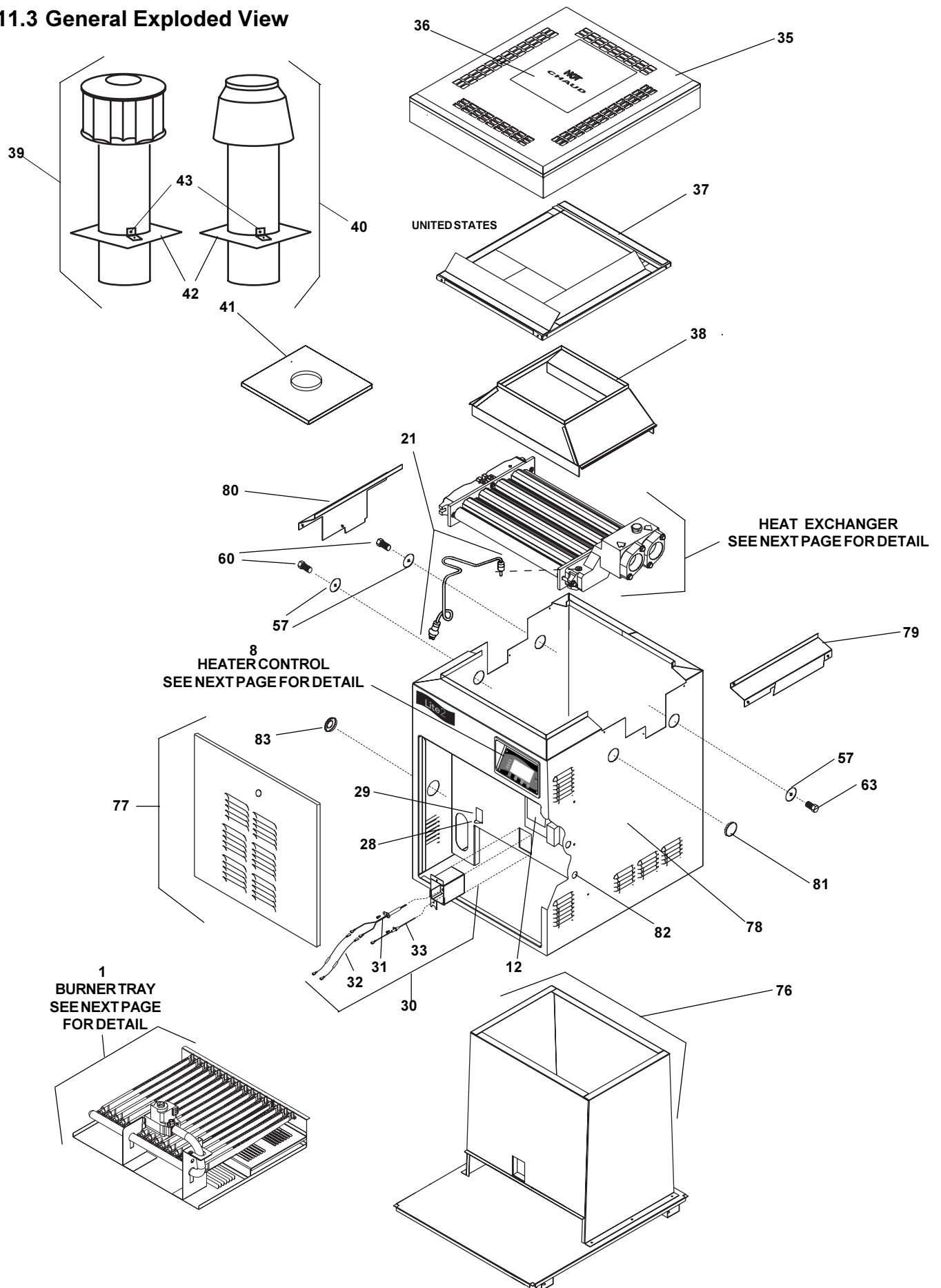

11.4 Detailed Exploded View

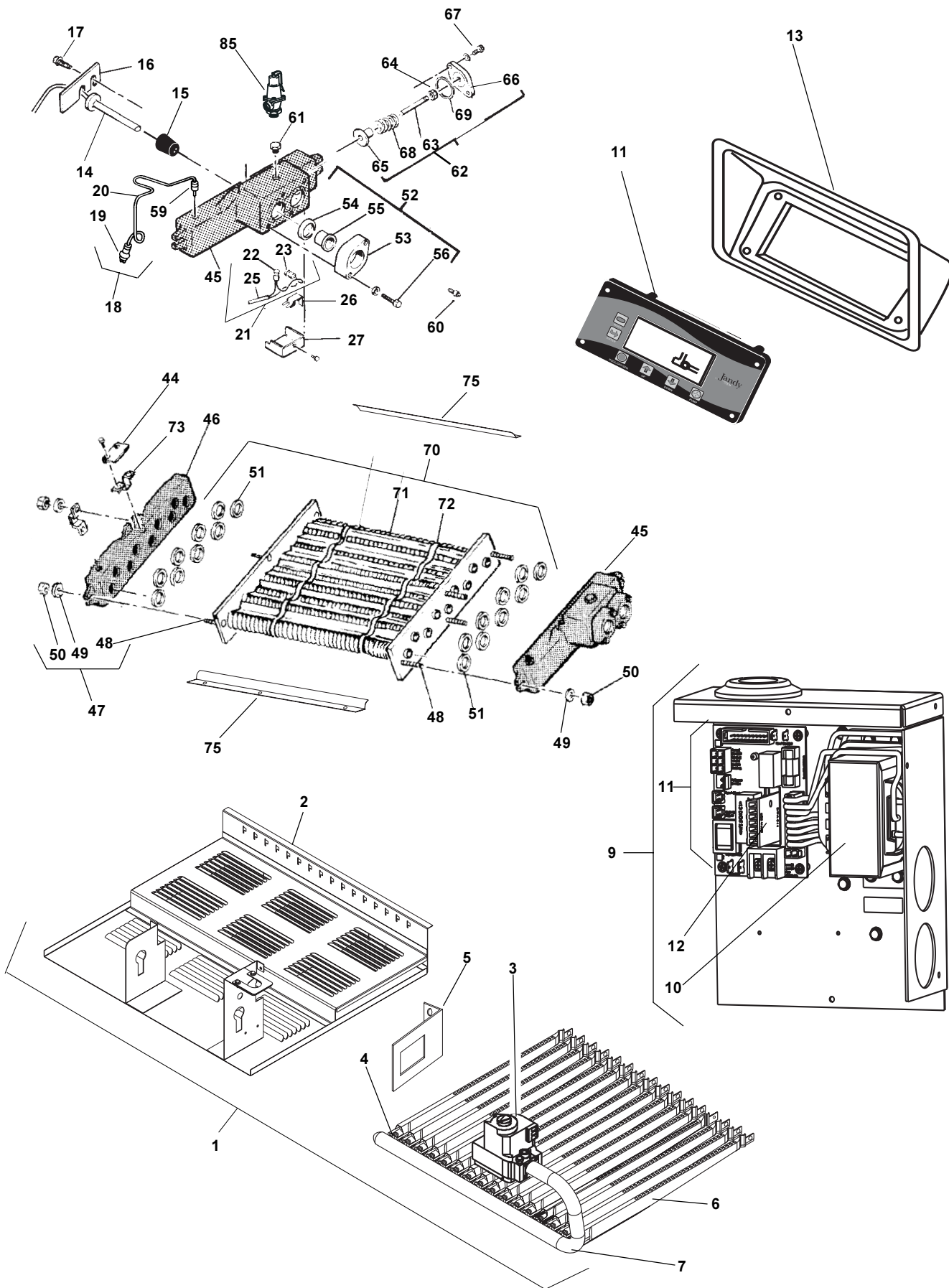

LIMITED WARRANTY

These warranties extend only to the first retail purchaser of Water Pik Technologies, Inc. and Jandy products that have not been moved from their original installation sites. Water Pik Technologies, Inc. and Jandy warrants all parts to be free from manufacturing defects in material and workmanship as detailed below for the designated time frame, commencing from the date of installation. If any parts are found to have manufacturing defects, Water Pik Technologies, Inc. and Jandy will provide replacement of such defective parts.

	<u>1 year</u>	<u>2 years</u>	<u>3 years</u>	<u>5 years</u>	<u>Lifetime</u>
Cleaners:					
Ray-Vac®		X			
Others	X				
Control Systems:					
AquaLink® RS and Accessories	X				
AquaLink® RS (w/Surge Protection)	X	X(\$50 Deductable)	X(\$75 Deductable)		
AquaSwitch®, Pool Control, Ji, and Solar Control	X				
Filters:	X			Tank	
Heaters:					
Lite2		Controls, Firebox Panels, Heat Exchanger, Burners		All Other Parts	
LX, Hi-E2		Controls, Firebox Panels, Heat Exchanger, Fan Motor, Burners		All Other Parts	
Hot Shot	X				
Oil-Fired, XL-2, XL-3		Oil Burner, Controls, Heat Exchanger, Firebox		All Other Parts	
Pumps:	X	Motor (from Manufacturer)			
Jandy Valve Actuator:	X				
Valves:					
NeverLube®					X
Others	X				
Water Features:	X				

EXCLUSIONS:

The liability of Water Pik Technologies, Inc. and Jandy shall not exceed the repair or replacement of defective parts and does not include any costs for labor to remove and reinstall the defective part, transportation to or from the factory, and any other materials required to make the repair.

This warranty does not cover failures or malfunctions resulting from the following:

1. Failure to properly install, operate or maintain the product(s) in accordance with our published Installation, Operation and Maintenance Manuals provided with the product(s);
2. The workmanship of any installer of the product(s);
3. Not maintaining a proper chemical balance [pH level between 7.2 and 7.8, Total Alkalinity (TA) between 80 to 120 ppm, Total Dissolved Solids (TDS) less than 2000];
4. Abuse, alteration, accident, fire, flood, lightning, rodents, insects, negligence or acts of God;
5. Scaling, freezing, or other conditions causing inadequate water circulation;
6. Operating the product(s) at water flow rates outside the published minimum and maximum specifications;
7. Use of non-factory authorized parts or accessories in conjunction with the product(s);
8. Chemical contamination of combustion air or improper use of sanitizing chemicals such as, introducing sanitizing chemicals upstream of the heater and cleaner hose or through the skimmer;
9. Overheating, incorrect wire runs, improper electrical supply, collateral damage caused by failure of O-Rings, DE grids, or cartridge elements, damage caused by running the pump with insufficient water;
10. The installation of a surge protection kit does not extend the warranty of the original product(s).

LIMITATION OF LIABILITY:

This is the only warranty given by Water Pik Technologies, Inc. and Jandy. No one is authorized to make any other warranties on Water Pik Technologies, Inc. and Jandy behalf. **THIS WARRANTY IS IN LIEU OF ALL OTHER WARRANTIES, EXPRESS OR IMPLIED, INCLUDING BUT NOT LIMITED TO ANY IMPLIED WARRANTIES OF FITNESS FOR A PARTICULAR PURPOSE AND MERCHANTABILITY. WATER PIK TECHNOLOGIES, INC. AND JANDY EXPRESSLY DISCLAIMS AND EXCLUDES ANY LIABILITY FOR CONSEQUENTIAL, INCIDENTAL, INDIRECT OR PUNITIVE DAMAGES FOR BREACH OF ANY EXPRESS OR IMPLIED WARRANTY.** This warranty gives you specific legal rights, and you may also have other rights which vary from state to state or by province.

WARRANTY CLAIMS:

For prompt warranty consideration, contact your dealer and provide the following information: proof of purchase, model number, serial number and date of installation. The installer will notify the factory for instructions regarding the claim and for the location of the nearest Jandy designated service center. If the dealer is not available, you can locate a service center in your area by visiting www.jandy.com or you can call the Technical Support Department at (707) 776-8200 ext. 260 for assistance. All returned parts must have a Returned Material Authorization number in order to be considered for warranty evaluation. If there are any questions about the coverage of this warranty, please contact Jandy at the address below.



6000 Condr Drive, Moorpark, CA, USA 93021 • 707.776.8200 FAX 707.763.7785
480 S. Service Road West, Oakville, Ontario, Canada L6K 2H4 • 905.844.8233 FAX 905.844.2635

Litho in U.S.A. © Water Pik Technologies, Inc. 0503

H0248900B